

Sitron's CF Line of Flow Switch Monitors

Models:

- CF 12AC
- CF 12DC
- CF 420
- F 420 – RCF 420

Introduction

Sitron's versatile and intelligent line of **Thermal Dispersion Flow Switch Monitors** are compact switches, with no moving parts, that can monitor and control the flow of liquid, air, and gas in pipes and ducts. They can also be used for single point level control of liquid or for interface detection between mediums. Sitron's series of flow switches are available in five different models that provide for different power supply, output, environmental and connection requirements.

All models are manufactured using 316 stainless steel and can be coated when necessary for aggressive applications. All of the CF 12 models can operate in temperatures up to 248°F (120°C) and have a maximum working pressure of 4500 PSI (300 bar). A display chain of 8 LED's is available for all models to indicate flow rate. Sitron also offers the option of sanitary connections such as Tri-Clamp as well as the standard threaded connections. In addition, after the process connection has been tightened, the orientation of the enclosure can be rotated so that the LED display can be best viewed.

Sitron's line of flow switch monitors are highly reliable industrial instruments that provide the durability and speed required for today's general as well as harsh process environments for flow and level.

Technology

Sitron's CF line of thermal flow switch monitors is based on the principle of thermal dispersion. A typical configuration uses two platinum Resistance Temperature Detectors (RTD's) set within the tip of the sensor. One RTD is heated a few degrees above the temperature of the medium and the other RTD is used as a reference, sensing the actual process temperature. The second RTD also monitors the temperature of the medium, as any changes in temperature must be compensated for in the first RTD. As the process medium flows over the tip of the sensor it disperses some of the heat from the first RTD. The temperature change between the two RTDs signals the probe's electronics and the switch changes state once the set point has been reached. For the CF 420, the microprocessor-based electronics constantly updates and reviews the signals received, in return putting out a 4-20mA analog output signal, which is proportional to the flow rate.

Features

- Simple to install & low in cost
- No moving parts-maintenance free reliability
- Optimal temperature compensation - unaffected by temperature gradient
- Can operate in temperatures up to 248°F (120°C)
- Have a maximum working pressure of 4500 PSI (300 bar).
- Choice of output signal
- Chain of 8 LED's-Integrated flow rate/set point indication
- Fast response time for flow or level (Adjustable from 1-10 seconds)
- Excellent low flow sensitivity
- Can be coated for aggressive mediums
- Insensitive to dirt and most particles
- Available in EX-Proof version
- Available in threaded, flange, sanitary and adjustable insertion length connections



CF 12 AC - Power Supply: 85...240 VAC/ Switch Output

The **CF 12 AC** is a thermal flow switch monitor designed to monitor flow status and also used to detect level of liquids, air and gas. A chain of 8 LED's gives the user a visual indication of the flow rate. In addition, there is also a di-chromatic LED, which shows the switch point status of the unit. The sensing element and connection of the CF12 AC is made with 316 S.S. and the enclosure is glass filled nylon. The CF12AC can be made with a great variety of process connections such as threaded, flange, or sanitary and can be coated when necessary.

This model is also available in an **Explosion Proof (EX)** version with an aluminum enclosure, designed to detect flow and level of liquids and gas in hazardous environments.

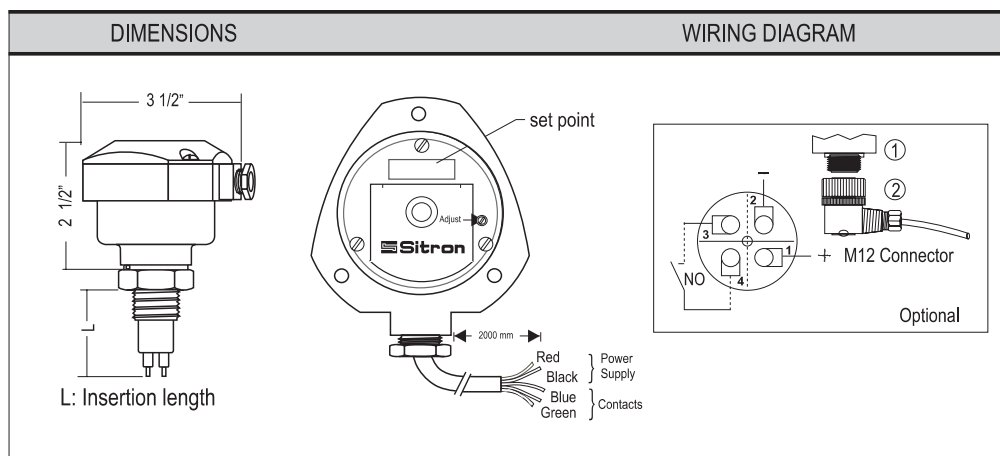



CF 12 DC - Power Supply: 24 VDC/ Switch Output

The **CF 12 DC** is a thermal flow switch monitor designed to monitor flow status and also used to detect level of liquids, air and gas. A chain of 8 LED's gives the user a visual indication of the flow rate. In addition, there is also a di-chromatic LED, which shows the switch point status of the unit. The sensing element and connection of the CF12 DC is made with 316 S.S. and the enclosure is glass filled nylon. The CF12DC can be made with a great variety of process connections such as threaded, flange, or sanitary and can be coated when necessary.

This model is also available in an **Explosion Proof (EX)** version with an aluminum enclosure, designed to detect flow and level of liquids and gas in hazardous environments.

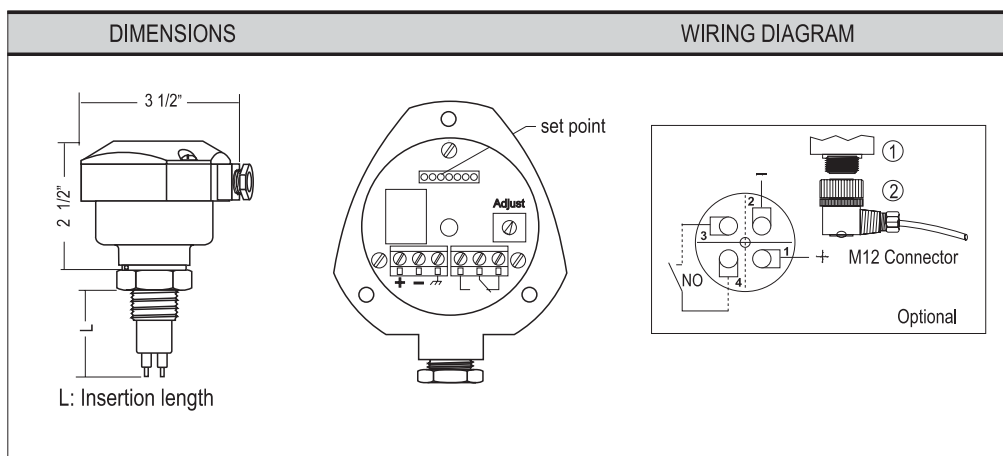



CF 420 - Power Supply: 24VDC Analog 4-20mA Output and PNP/NPN Switch Output

The **CF 420** model is a flow switch monitor that measures the velocity of the flow. It is ideal for use in measurement and control applications. The CF 420 provides two output options; a 4-20mA analog output and a PNP/NPN output. For the 4-20mA output, the electronics' module converts the signal from the probe to a 4-20mA analog output, which can be used to indicate flow rate. For the PNP/NPN output, the measured flow rate is compared to the set point value selected by the user and the switch changes state once the set point value has been achieved.

The CF 12's microprocessor based electronics and unique self-calibration program gives the flow switch superior temperature compensation, a fast response time (adjustable from 3 to 10 seconds) and increased long term switch point stability. Even in the event of a power failure, the calibration program will store values for maximum and minimum flows for up to 10 years.

A chain of 8 LED's gives the user a visual indication of the flow rate as well as set point status, and one di-chromatic LED indicates switch point status. In addition, if there is a problem with the unit, the 8 LED's will flash continuously providing troubleshooting information.

The conical shape of the sensor's tip means that the probe can be installed at almost any angle in the pipe and that if the probe is miss-aligned, accuracy will not be affected. The sensing element and connection of the CF420 are made with 316 S.S., can be coated when necessary and the enclosure is glass filled nylon. The CF420 can be made with a great variety of process connections such as threaded, flange, or sanitary and is also available in an Explosion Proof version with an aluminum enclosure for hazardous environments.

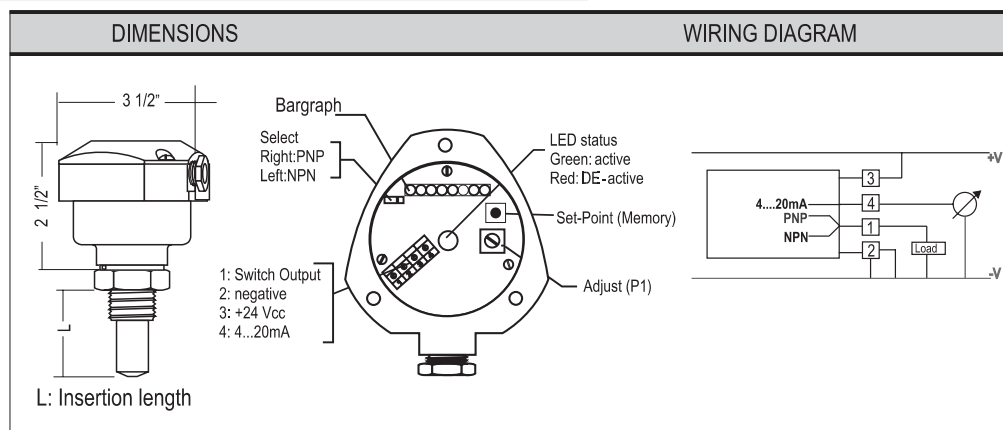

Measuring Ranges for CF420

The CF 420's nominal measuring range is 0.04 to 2.0 m/s. The switch can be set to trip at any value in this range. To calculate the velocity for your application, use the following simple formula:

$$V = \frac{1.27 \times Q}{D^2}$$

Q = Flow rate in m³ per second

D = Pipe internal diameter in meters

V = Fluid velocity in meters per second

Please note that the 4-20mA option is scaled over 0 to 2.0 m/s



F420 Sensor + RCF 420 Flow Switch Relay

The **F420** is very similar to the CF420 with one main difference: The sensor is separate from the electronics and it does not have an enclosed housing. This gives the F420 the ability to be installed in very small pipes, and be remotely controlled by the RCF420 relay. The F420 is the ideal solution when there is not a lot of space to install even a compact unit or when there is a need for a mounted relay. In addition, the conical shape of the sensor's tip allows the probe to be installed at almost any angle in the pipe, and if it is miss-aligned, accuracy will not be affected. The F420 is entirely made

with 316 S.S. and can be (Teflon) coated when necessary. The RCF420 relay can operate with DC and AC supply voltage and provides an analog 4-20mA and SPDT output. The RCF420 enclosure is made with ABS and can be mounted on a DIN rail or by using 2 fixing screws.

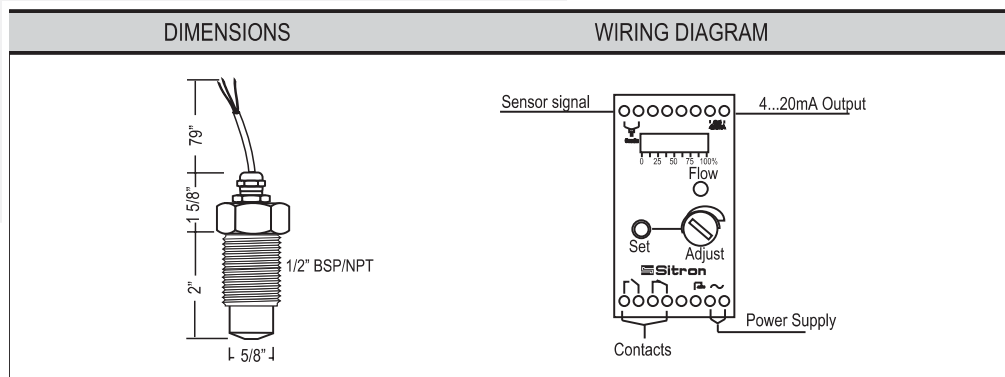

SPECIFICATIONS

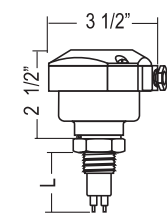
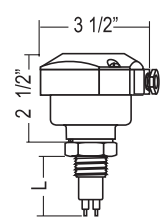
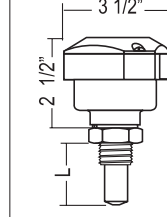
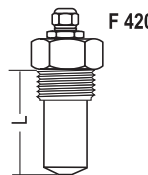
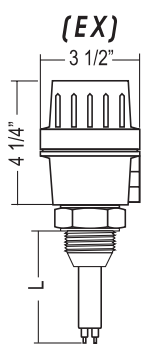
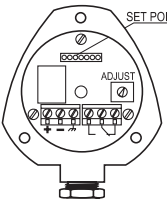
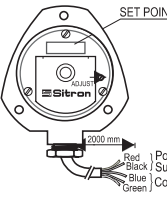
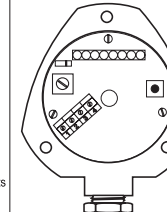
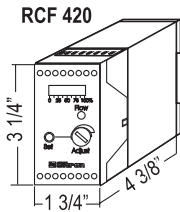
MODELS	CF 12 DC	CF 12 AC	CF 420	F 420	CF 12 AC EX CF 12 DC EX CF 420 EX
					
					
Application	Flow for liquids and gas level for liquids only	Flow for liquids and gas level for liquids only	Flow for liquids	Flow for liquids	Flow for liquids and gas level for liquids only
Operating Voltage	DC - 24 Vdc +/- 10%	AC - 85...240Vac and 125 Vdc	DC - 24 Vdc +/- 10%	DC - 24 Vdc +/- 10% AC - 85...240Vac and 125 Vdc	DC - 24 Vdc +/- 10% AC - 85...240Vac and 125 Vdc
Current Consumption	Max. 1VA	Max. 1VA	Max. 1VA	Max. 1VA	Max. 1VA
Output	Relay (SPDT) 5A max (250Vac)	Relay (SPDT) 5A max (250Vac)	4-20mA and transistor NPN/ PNP (400mA)	4-20mA and relay (SPDT)	See specs for each model
Set point range	2 cm/s to 3m/s	2 cm/s to 3m/s	0.04 to 2m/s - water 0.1 to 4m/s - oil	0.04 to 2m/s - water 0.1 to 4m/s - oil	See specs for each model
Electrical connection	Cable entry or M12 connector	Cable entry with 6.57ft (2000mm) cable or M12 connector	Cable entry or M12 connector	Cable entry with 6.57ft (2000mm) cable or M12 connector	1/2" or 3/4" NPT
Operating Temperature	14 to 176° F (-10 to 80°C) sanitary option to 248°F (120°C)	14 to 176° F (-10 to 80°C) sanitary option to 248°F (120°C)	14 to 176° F (-10 to 80°C) sanitary option to 248°F (120°C)	Sensor: 14 to 176° F (-10 to 80°C) sanitary option to 248°F (120°C)	14 to 176° F (-10 to 80°C)
Gradient Temperature	not affected	not affected	not affected	not affected	not affected
Accuracy	Typical +/- 10% setpoint	Typical +/- 10% setpoint	Typical +/- 10% setpoint	Typical +/- 10% setpoint	Typical +/- 10% setpoint
Response time	1 to 10 seconds	1 to 10 seconds	3 to 10 seconds	3 to 10 seconds	See specs for each model
Repeatability	+/- 1% setpoint	+/- 1% setpoint	+/- 1% setpoint	+/- 1% setpoint	+/- 1% setpoint
Flow rate indication	8 LED's bar graph Red led - flow is below setpoint Yellow led - flow is at above setpoint Green led - flow rate above setpoint	8 LED's bar graph Red led - flow is below setpoint Yellow led - flow is at above setpoint Green led - flow rate above setpoint	8 LED's bar graph	8 LED's bar graph	See specs for each model
Process connection	1/2" to 1 1/2" BSP or NPT, adjustable, flange and sanitary	1/2" to 1 1/2" BSP or NPT, adjustable, flange and sanitary	1/2" to 1 1/2" BSP or NPT, adjustable, flange and sanitary	1/2" BSP or NPT, adjustable, flange and sanitary	1/2" to 1" NPT flange or sanitary
Wetted material	316 Stainless steel	316 Stainless steel	316 Stainless steel	316 Stainless steel	316 Stainless steel
Enclosure material	Glass filled nylon	Glass filled nylon	Glass filled nylon	Relay ABS	Alluminum Die Cast Explosion Proof
Max pressure	4408 PSI (300 Bar)	4408 PSI (300 Bar)	4408 PSI (300 Bar)	4408 PSI (300 Bar)	4408 PSI (300 Bar)
Class Protection	IP 65	IP 65	IP 65	IP 65	NEMA 4X

EXAMPLES OF APPLICATIONS

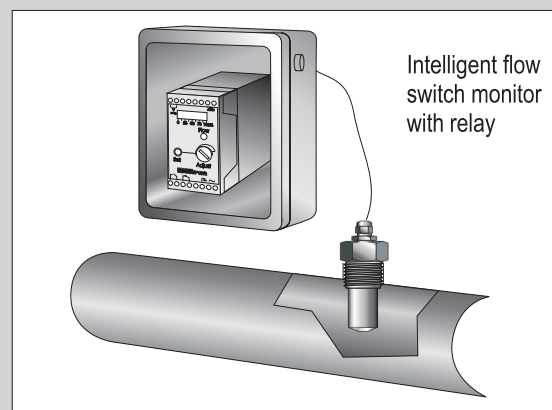
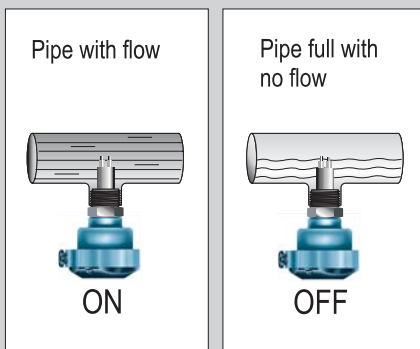
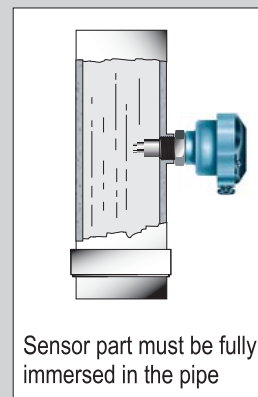
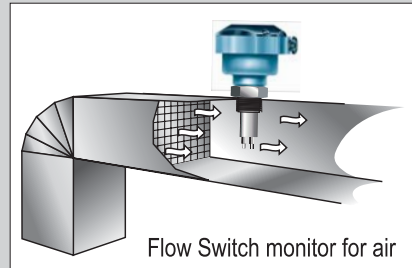
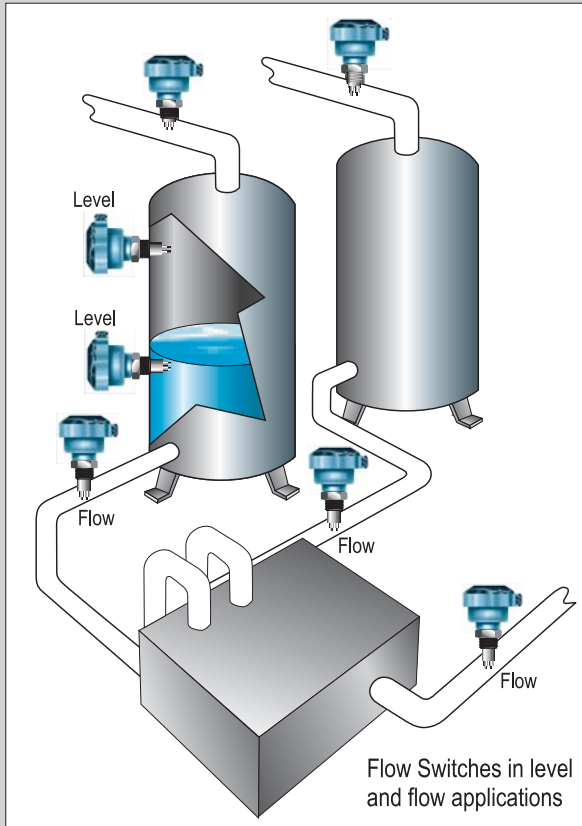

ORDERING INFORMATION

Code	Specifications
CF12AC	Supply Voltage: 85...240 VAC Output: Relay (SPDT) 250VAC - 5A max
CF12DC	Supply Voltage: 24 VDC + - 10% Output: Relay (SPDT) 250VAC - 5A max
CF420	Supply Voltage: 24 VDC + -10% Output: 4-20mA & transistor NPN/PNP

Code	Process Connection
1	1/2" Thread
2	3/4" Thread
3	1" Thread
4	Adjustable connection with 1/2" thread
5	1 1/2" Tri-Clamp
6	Flange 2" ANSI, 150lb. 316 S.S.
7	Other - Specify

Code	Type of thread
B	BSP
N	NPT
X	Not a thread

Code	Body Material
SS	316 S.S. (all models)
HH	Hastelloy-C (only CF420)

Code	Insertion length
35	L=1 3/8" (35mm)
50	L=2" (50mm)
75	L=3" (75mm)
X	Other - Specify

Code	Enclosure
NY	Glass filled nylon
EX	Aluminum die cast

Code	Electrical Connection
C	Cable entry
M	M12 connector
1/2"	1/2" NPT (for aluminum enclosure only)
3/4"	3/4" NPT (for aluminum enclosure only)

ORDERING INFORMATION FOR FLOW SWITCH W/ RELAY

Code	Model
F420	F420 - with 1/2" BSP thread and cable with 6.5ft. (2000mm) - L= 2" (50mm)

Code	Relay
DC	RCF - Relay for Flow Switch - Supply Voltage: 24VDC + - 10%
AC	RCF - Relay for Flow Switch - Supply Voltage: 85...240VAC

Note: PTFE coating optional for aggressive products for models CF12AC and DC