

GAS and OIL OPERATED BUCHHOLZ RELAY

with Mercury / Magnetic reed switch for Oil Filled Transformer

Pipe Bore Size: 25mm and 50 mm.



ISO 9001:2015 CERTIFIED

FEATURES & CHARACTERISTICS:

- ❖ Mounting dimension and test parameter as per Indian standard: 3637-1966.
- ❖ Graded aluminium alloy of relay cover and graded CI body/ housing.
- ❖ Functional test of alarm and trip contacts with continuity test lap possible even without filling the relay with oil.
- ❖ Unique design of internal housing and cover prevents falls air traps on top of the relay.
- ❖ Well design internal layout gives clear view of colour of gas inside the relay through glass window for fault analysis.
- ❖ Bucket type float design with inherent ability to withstand vacuum treatment of transformer.
- ❖ Extra anti vibration mounting pads introduce for magnetic switches to give high stability against mechanical shocks and vibrations.
- ❖ Normally open/ normally closed/ change over contacts.



APPLICATION:

Double element relays can be used in detecting minor or major faults in a transformer. The alarm element will operate, after a specified volume of gas has collected to give an alarm indication. The alarm element will also be operate in the event of oil leakage, or if air gets into the oil system.

The trip element will be operated by an oil surge in the event of more serious faults such as earth faults, winding short circuits, puncture of bushings, and short circuit between phases.

The trip element will also be operating if a rapid loss of oil occurs. Single element relay can be used to detect either incipient or major faults in oil filled potential transformers, reactors, capacitors etc. A special single element relay is available for the protection of on load tap change equipment.

CONSTRUCTION & WORKING:

A Buchholz relay is designed keeping in view the various aspects. The cast body must be to withstand 8kg/cm² pressure for 1 minute and when a complete assembled relay is tested at 1.5 kg/cm² pressure it must show no sign of leakage. High voltage and insulation resistance tests are also conducted. The relay has housing in which two floats one over the other are present. These floats may be bucket type. Each of these floats have one switch (mercury, or reed switch) mounted in such a way that the lowering of float activates the switch. The switch leads are brought out on the terminal box.

The function of a double element relay described here. During normal operation of a transformer the Buchholz relay is completely filled with oil. Buoyancy and the moment due to counter weights keep the floats in their original top positions. In the event of some fault in the interior of transformer tank, gas bubbles are produced, which accumulate in the Buchholz relay on the way to the conservator. In consequence, the oil level in the relay enclosure drops which in turn lowers the upper bucket.

Thus triggering the upper switching system to operate i.e. Alarm.

In case the liquid continues to drop due to loss of oil, the lower bucket also goes down. In consequence, the lower switching system operates if the level of oil goes below the bottom level of the pipe connected to the relay. Alternately in the event the liquid flow exceeds a specific value the lower bucket is forced down, thus triggering the lower switching system to operate i.e. Trip.

As the liquid flow rate decreases, or the level of the liquid rises, the bucket returns to its original position. The single element relay has only trip element and it responds to only oil surges. The method of operation is similar to that described for double element relay. Single element relays are suitable for potential transformer and on load tap changers.

The single element oil surge relay has been specifically designed for use with on load tap change equipment and it will bypass normal amounts of gas which are generated by tap change operations and will only respond to oil surges and loss of oil.

ELECTRICAL CONNECTION:

To allow installation open the terminal box cover comprising of the name plate and the instruction sticker on the backside. Then pass the wire through one of the conduit screwing into the terminal box. The upper two studs are terminal for the alarm switching circuit and are denoted by A Likewise, the lower two studs are terminals for the trip switching circuit and are denoted by T.

INSTALLATION & MAINTENANCE:

Installation into pipeline: For installing the relay into pipe line proceed as follows:

- ❖ See that the Buchholz Relay is positioned with the arrow pointing towards the conservator, the connection box is the Y plan (vertical) and the Test cock and air vent cock are at the top.
- ❖ Mount the Buchholz Relays as close as possible to the tank in the pipe line between transformer and conservator.
- ❖ Keep pipe bends as wide as possible. Avoid close bends.
- ❖ Make sure pipe ascends to the conservator at angle between two degrees to five degrees.
- ❖ Ensure that locking key remains in locked position during storage or loose transportation of the relay.
- ❖ Ensure that the locking key remains in the service position before commissioning of the relay.

FUNCTIONAL TEST:

Loosen the M10 nut of locking key with box wrench for checking the continuity of alarm and trip contacts. While checking the continuity ensure the relay is kept between 2° to 5° inclined position as in the pipe line of a transformer.

SPECIFICATIONS:

Parameter	GOR-1	GOR-2
Alarm for gas accumulation	90 - 165cc	200 - 225cc
Trip for steady oil flow	70 - 130 cm/sec	75 - 140 cm/sec
High voltage test	2KV at 50 Hz. for 60 Sec.	
Insulation Resistance Test	500V Meggar	
Porosity test	No leakage with air at 3kg/cm	
Current rating of switch	5/2Amp at 250V AC/DC Respectively applied (3amps 110V DC). Pressure test 3kg/cm ² for 72 hrs.	
Type of contacts	Normally open type/ Normally closed/ change over	
Housing strength	8kg/cm ² for 2minutes	
Magnet used	Rare earth	
Mounting position	2° to 5° ascending towards conservator	
Working temperature in oil	-25° to +115°C viscosity 1mm ² /sec to 100mm ² /sec	
Enclosure Protection	Exposure to dust and moisture as per IP x X7 classification of EN 60529-1966	

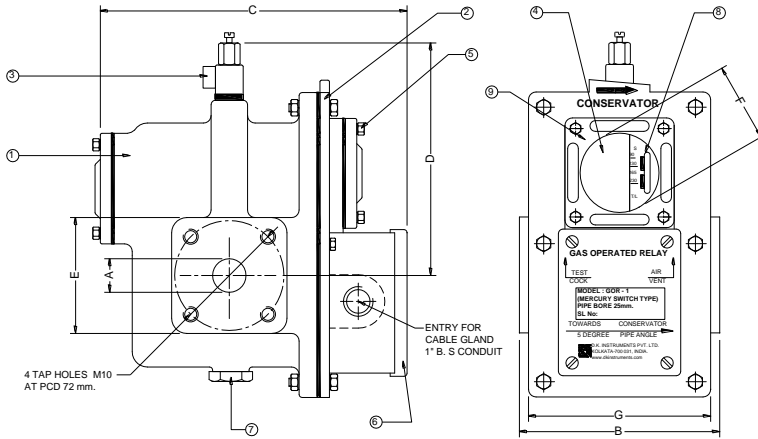

Model: GOR-1

PARTS LIST		
SL.	DESCRIPTION	MATERIAL / MFG.
1	BODY	C.I
2	B/R LID	ALUMINUM ALLOY
3	TEST COCK & AIR VENT VALVE	FORGED ALUMINUM
4	WINDOW GLASS	TOUGHENED GLASS
5	HARDWARE ITEM FOR ASSY.	BRASS & STEEL
6	TERMINAL COVER	ALUMINUM ALLOY
7	DRAIN PLUG	STEEL
8	MEASURING	ALUMINUM
9	WINDOW GLASS COVER	ALUMINUM ALLOY

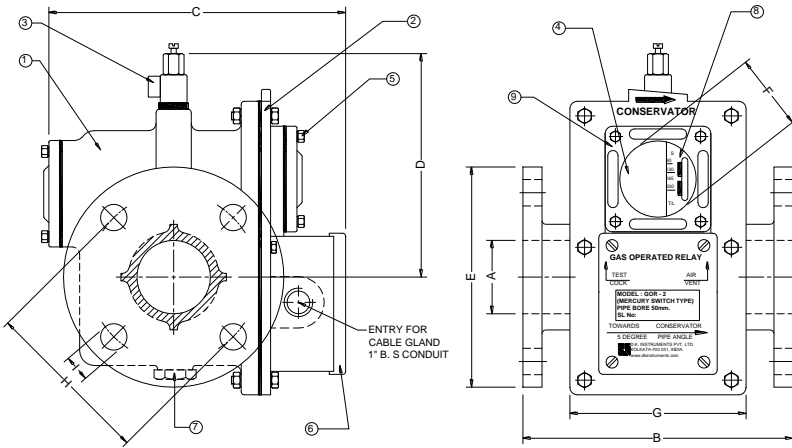

Model: GOR-2

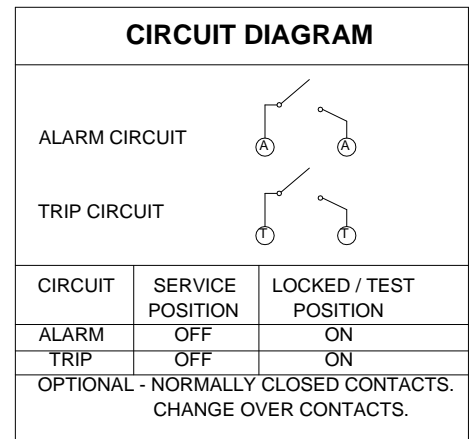

MODEL	SIZE/ NOM. PIPE BORE 'A'	ALL DIMENSION ARE IN MM								MOUNTING HOLES	SUITABLE FOR TRANSFORMER RATING	APPROX Wt. IN (Kgs)
		B	C	D	E	F	G	H	I			
GOR - 1	Ø25	127+1	200	145~	SQ 78	Ø52	120	-	-	-	UPTO 1 MVA	6.7
GOR - 2	Ø50	184	200	133~	Ø150	Ø52	120	Ø115	Ø18	4 Nos.	2 TO 10 MVA	9.5

D.K. INSTRUMENTS PVT. LTD.
 76/2 Selimpur road, Dhakuria, Kolkata – 700031. India
 Ph. No. : 91-33-2415 1310 / 2405 0944,
 E-mail: info@dkinstruments.com
 Web site: www.dkinstruments.com