

FAG



FAG Equipment and Services for the Mounting and Maintenance of Rolling Bearings

For increased operational reliability of rolling bearing arrangements

About this catalogue

This catalogue is aimed principally at maintenance managers responsible for plant in which rolling bearings and other rotating machine components play a critical role in determining the quality of products and processes.

Maintenance managers are responsible for the maintenance and production process. They must be able to rely every day on the quality of their tools and the expertise of their service providers.

FAG Industrial Services (F'IS) therefore offers high quality products, services and training. This catalogue gives a complete guide to the range on offer from F'IS.

F'IS employees and their certified partners will be pleased to help you select the ideal products, services and training for your needs.

Dr.-Ing. Bernd Geropp and
Dr.-Ing. Hans-Willi Kessler
Managing Directors of
FAG Industrial Services



Questions and ideas on this catalogue
should be sent to

FAG Kugelfischer AG & Co. oHG
Postfach 1260 · D-97419 Schweinfurt
Georg-Schäfer-Straße 30 · D-97421 Schweinfurt
Service Hotline:
Telephone: +49 2407 9149-99
E-Mail: support@fis-services.de
www.fis-services.de

The address of the representative responsible for your particular country can be found on the last cover page.

FAG Industrial Services – Competence in Maintenance

FAG Industrial Services

Since the beginning of 2001, FAG Kugelfischer has concentrated its independent service business through FAG Industrial Services GmbH (F'IS) based in Herzogenrath, near Aachen. Since the integration of FAG into the Schaeffler Group, F'IS has undertaken service tasks for the whole Group.

F'IS is a specialist contact for the maintenance of rotating components. The aim is to help customers save on maintenance costs, optimise plant availability and avoid unforeseen machine downtime.

The services are provided irrespective of the brand of the

machine components used. In order to provide a rapid, competent supply of F'IS products, services and training to customers worldwide, F'IS has Centres of Excellence around the world. These work together with local partners that are certified and regularly audited by F'IS.

Since each customer has a different set of requirements, F'IS offers concepts individually tailored to the customer. The quality requirements are strongly influenced by the history, going back more than 100 years, of high precision rolling bearing manufacture at FAG.

Each tool, accessory and grease in this catalogue, has been subjected to intensive testing in practical use and classified as being of high quality.

The F'IS range

F'IS has undertaken ongoing expansion of its range in recent years.

F'IS offers products, services and training in the following five areas:

- Mounting/Repair
- Lubrication
- Alignment
- Condition monitoring
- Maintenance management

Overview
(For details, please consult
the contents list)

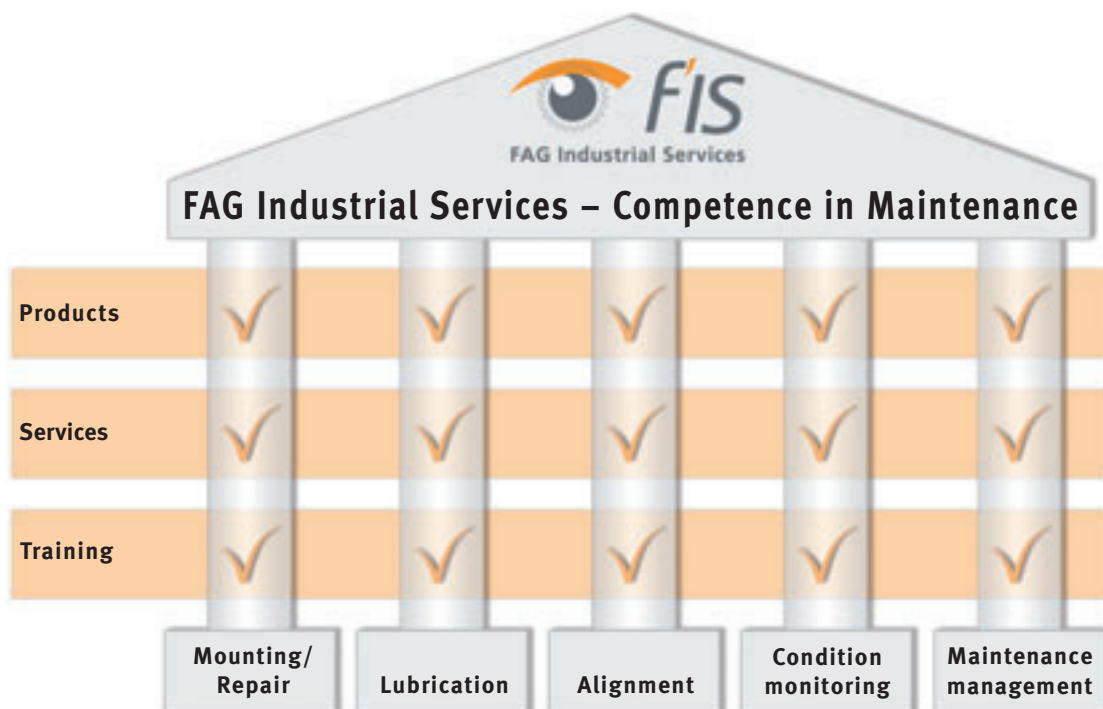

Contents

Products 7

Mounting/Repair	8
Lubrication	43
Alignment	55
Condition monitoring	61
Maintenance management	69

Services 71

Mounting/Repair	72
Lubrication	76
Alignment	77
Condition monitoring	78
Maintenance management	81

Training 85



















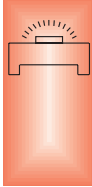
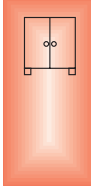



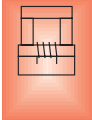
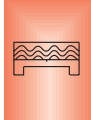

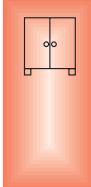





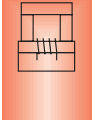

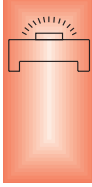
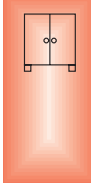





Mounting/Repair	87
Lubrication	88
Alignment	88
Condition monitoring	89
Maintenance management	92







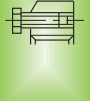







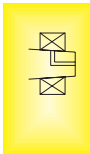









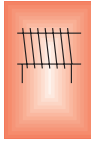

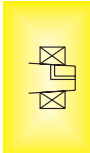

















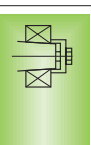

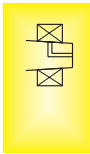





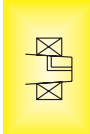

Publications 95

Index of FAG products 97

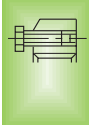
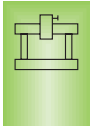
Tools for mounting and dismounting

Overview

Bearing type	Bearing bore	Bearing size	Mounting				
			With heating				Without heating
 Deep groove ball bearings  Tapered roller bearings  Angular contact ball bearings  Barrel roller bearings  Four point contact bearings  Spherical roller bearings  Self-aligning ball bearings	Cylindrical	Small					
		Medium-sized					
		Large					
 Cylindrical roller bearings  Needle roller bearings	Cylindrical	Small					
		Medium-sized					
		Large					
 Thrust ball bearings  Angular contact thrust ball bearings  Cylindrical roller thrust bearings  Spherical roller thrust bearings	Cylindrical	Small					
		Medium-sized					
		Large					
 Self-aligning ball bearings  Barrel roller bearings with adapter sleeve  Spherical roller bearings with adapter sleeve  Spherical roller bearings with withdrawal sleeve  Adapter sleeve  Withdrawal sleeve	Tapered	Small					 
		Medium-sized					
		Large					
 Cylindrical roller bearings, double row	Tapered	Small					
		Medium-sized					
		Large					

	Hydraulic method	Dismounting		Hydraulic method	Symbols
		With heating	Without heating		
			  		 Induction heating device  Heating plate  Hot air cabinet  Heating cabinet  Oil bath  Induction heating device (coil)  Heating ring  Hammer and mounting sleeve
		 	 		 Hammer and mounting sleeve  Mechanical and hydraulic presses  Double hook wrench  Nut and hook wrench  Socket wrench  Nut and mounting screws  End cap  Hydraulic nut
			 		 Mechanical and hydraulic presses  Double hook wrench  Nut and hook wrench  Socket wrench  Nut and mounting screws  End cap  Hydraulic nut
 			  		 Socket wrench  Nut and mounting screws  End cap  Hydraulic nut
			   		 Hammer and drift  Extraction device  Hydraulic method

Products · Mounting/Repair

Mechanical mounting and dismantling 8

Mounting tool sets	8
Socket wrenches	9
Hook and pin wrenches	9
Mechanical extractors	12
Hydraulic extractors	15
Three-section extraction plates	17

Hydraulic mounting and dismantling 19

Hydraulic nuts	19
Mounting Manager	21
Overview of pressure generation devices	22
Oil injectors	24
Hand pump sets	25
High pressure pumps	26
Hydraulic systems and units	27
Connectors, accessories	28

Thermal mounting and dismantling 31

Electric heating plate	31
Induction heating devices	31
Heating rings, heat conducting paste	34
Electric induction heating devices (coils)	35

Measurement and inspection 36

Feeler gauges	36
Taper gauges	36
Snap gauge	38
Enveloping circle gauges	39

Accessories 40

Transport and mounting tool	40
Gloves	41
Mounting paste	42
Anti-corrosion oil	42



Products · Mounting/Repair

Mechanical mounting and dismounting

Mounting tool sets

FAG mounting tool sets FITTING.TOOL.ALU.SET10-50 and FITTING.TOOL.STEEL.SET10-50

FAG fitting tool sets allow economical and secure mounting of rolling bearings up to 50 mm bore. They can also be used to easily mount sleeves, intermediate rings, seals and similar parts.

Where inner or outer rings with a tight fit are to be driven onto a shaft or into a housing bore respectively, this can be achieved by applying hammer blows to an appropriate mounting sleeve. This prevents the mounting forces from being transmitted through the rolling elements and raceways, which can lead to damage. The carefully matched FAG precision parts ensure that the forces are uniformly transmitted to the side faces of the bearing rings.

The FITTING.TOOL.ALU.SET10-50 has mounting sleeves made from aluminium and mounting rings made from plastic. The parts are economical and easy to use. The steel mounting sleeves and steel mounting rings in the FITTING.TOOL.STEEL.SET10-50 give long wear-free operating life. These tools can also be used in conjunction with workshop power presses.

FAG mounting tool sets FITTING.TOOL.ALU.SET10-50 and FITTING.TOOL.STEEL.SET10-50

Included in delivery	Ordering designation FITTING.TOOL.ALU.SET10-50	FITTING.TOOL.STEEL.SET10-50
Mounting rings	33 pieces	33 pieces
For bearing bore	10 – 50 mm	10 – 50 mm
Outside diameter up to	110 mm	110 mm
Mounting sleeves	3 pieces	5 pieces
Hammer, recoilless	1 kg	0,7 kg
Dimensions of case	440×350×95 mm	370×320×70 mm
Mass of complete set	4,5 kg	21 kg
Also available as individual parts		

For detailed information, see
TI WL 80-56.



Products · Mounting/Repair

Mechanical mounting and dismounting

Socket wrenches and hook wrenches for mounting and dismounting

FAG socket wrenches

LOCKNUT.SOCKET...

For locknuts KMo to KM20

Locknuts can be easily tightened and loosened on shafts, adapter sleeves and extraction sleeves using FAG socket wrenches LOCKNUT.SOCKET...

They require less space on the circumference of the nut than hook wrenches and allow the use of ratchets and torque wrenches. For increased reliability, socket wrenches should be secured using a locking pin and rubber washer. FAG socket wrenches therefore have a hole for the locking pin and a groove for the rubber washer. The locking pin and rubber washer are included in the delivery.

Ordering example for FAG socket wrench, suitable for locknut KM5:
LOCKNUT.SOCKET.KM5

For detailed information, see TI WL 80-56.

FAG hook wrenches

LOCKNUT.HOOK...

For locknuts from KMo and precision locknuts from LNPG017

FAG hook wrenches of series LOCKNUT.HOOK... (former FAG designation: HN../..) can be used to tighten and loosen locknuts (precision locknuts) on shafts, adapter sleeves and withdrawal sleeves.

FAG hook wrenches can be used to mount small bearings on tapered shaft seats, adapter sleeves or extraction sleeves.

Withdrawal sleeves can also be dismounted using FAG hook wrenches together with the extraction nuts.

Ordering example for FAG hook wrench, suitable for locknuts KM18, KM19, KM20:

LOCKNUT.HOOK.KM18-20
(former designation: HN120/130)

For detailed information, see TI WL 80-56.



Products · Mounting/Repair

Mechanical mounting and dismounting

Socket wrenches and hook wrenches for mounting and dismounting

FAG jointed hook wrenches LOCKNUT.FLEXI-HOOK...

For locknuts KM0 to KM40 and precision locknuts LNPG017 to LNPG200

FAG jointed hook wrenches of series LOCKNUT.FLEXI-HOOK... can be used to tighten and loosen locknuts (precision locknuts) on shafts, adapter sleeves and extraction sleeves if no torque value is specified.

The joint allows one hook wrench of series LOCKNUT.FLEXI-HOOK... to be used for mounting or dismounting locknuts of various sizes.

Ordering example for FAG jointed hook wrench, suitable for locknuts KM14 to KM24:

LOCKNUT.FLEXI-HOOK.KM14-24

For detailed information, see TI WL 80-56.

FAG jointed pin wrenches LOCKNUT.FLEXI-PIN...

For precision locknuts AM15 to AM90

FAG jointed pin wrenches of series LOCKNUT.FLEXI-PIN... can be used to tighten and loosen locknuts on shafts if no torque value is specified.

FAG jointed pin wrenches can be used to mount small bearings on tapered shaft seats.

Tightening is achieved by means of radially arranged holes.

Ordering example for FAG jointed pin wrench, suitable for locknuts AM35 to AM60:

LOCKNUT.FLEXI-PIN.AM35-60

For detailed information, see TI WL 80-56.

FAG jointed face wrenches LOCKNUT.FACE-PIN...

For precision locknuts LNPO17 to LNP170

FAG jointed face wrenches of series LOCKNUT.FACE-PIN... can be used to tighten and loosen precision locknuts on shafts if no torque value is specified.

FAG jointed face wrenches can be used to mount small bearings on tapered shaft seats.

Tightening is achieved by means of axially arranged holes.

Ordering example for FAG jointed face wrench, suitable for locknuts LNPO17 to LPNO25:

LOCKNUT.FACE-PIN.LNP17-25

For detailed information, see TI WL 80-56.



Products · Mounting/Repair

Mechanical mounting and dismounting

Socket wrenches and hook wrenches for mounting and dismounting

FAG double hook wrenches

For locknuts KM5 to KM13

FAG double hook wrenches are intended for the mounting of self-aligning ball bearings with a tapered bore. They are available as kits, sets or individual wrenches.

FAG double hook wrench kits

LOCKNUT.DOUBLEHOOK...KIT comprise a case containing a double hook wrench, a torque wrench and a user manual. The torque wrench allows a precisely defined tightening torque to be achieved at the start of the mounting operation.

FAG double hook wrench sets

LOCKNUT.DOUBLEHOOK...SET (former FAG designations 173556 and 173557) contain four or five double hook wrenches. The other items in the case are the same as in the kits.

Individual double hook wrenches

LOCKNUT.DOUBLEHOOK.KM5 to LOCKNUT.DOUBLEHOOK.KM13 (former designations DHN5 to DHN13) are also available. Each double hook wrench is engraved with the torsion angles for the self-aligning ball bearings to be mounted. Thus the sliding distance and reduction in radial internal clearance can be precisely set.

For detailed information, see TI WL 80-56.



Double hook wrench kits, e.g. LOCKNUT.DOUBLEHOOK.KM5.KIT and LOCKNUT.DOUBLEHOOK.KM13.KIT (FAG ordering designations)



Double hook wrench sets LOCKNUT.DOUBLEHOOK.KM5-8.SET and LOCKNUT.DOUBLEHOOK.KM9-13.SET (FAG ordering designations)



Double hook wrenches, e.g. LOCKNUT.DOUBLEHOOK.KM5 and LOCKNUT.DOUBLEHOOK.KM13 (FAG ordering designations)

Products · Mounting/Repair

Mechanical mounting and dismantling

Mechanical extractors

Mechanical FAG extractor PowerPull

Mechanical extractors can be used to dismount small rolling bearings up to approx. 100 mm bore diameter that are located with a tight fit on a shaft or in a housing. The bearing can be dismounted without damage, if the extractor is

in contact with the tightly fitted bearing ring.

In mechanical FAG extractors, the extraction force is normally applied by means of a threaded spindle. In addition to devices with two, three or four arms and a hydraulic pressure tool, FAG also offers special extraction devices.

For detailed information, see TI WL 80-56.

Note:
For dismounting larger bearings, hydraulic extractors should be used (page 15).

Two-arm extractor 54

- For extraction of complete rolling bearings or tightly fitted inner rings as well as other parts, e.g. gears
 - Grip width 80 – 350 mm, grip depth 100 – 250 mm
- Available as set (stand with 6 extractors) or individually

Ordering designation:

ABZIEHER54.SET
ABZIEHER54.100
ABZIEHER54.200
ABZIEHER54.300
ABZIEHER54.400
ABZIEHER54.500
ABZIEHER54.600

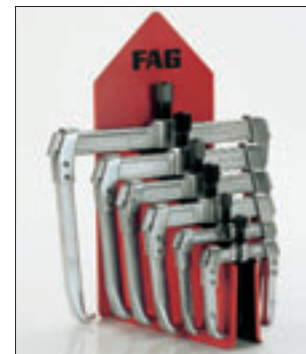

Two-arm bearing extractor 47

- For extraction of complete rolling bearings or tightly fitted inner rings
- Grip width 45 and 90 mm, grip depth 65 and 100 mm

Ordering designation:

ABZIEHER47.100
ABZIEHER47.200



Three-arm extractor 52

- For extraction of complete rolling bearings or tightly fitted inner rings
- Grip width 85 – 640 mm, grip depth 65 to 300 mm

Ordering designation:

ABZIEHER52.085
ABZIEHER52.130
ABZIEHER52.230
ABZIEHER52.295
ABZIEHER52.390
ABZIEHER52.640



Products · Mounting/Repair

Mechanical mounting and dismantling

Mechanical extractors

Hydraulic pressure tool 44

- For loosening of tightly fitted parts in conjunction with mechanical extractors
- Significant reduction in the effort required due to generation of an axial force of 80 or 150 kN, with a hydraulic return mechanism on the larger device

Ordering designation:

ABZIEHER44.080

ABZIEHER44.150



Ball bearing extractor 56

- For extraction of complete radial ball bearings
- For tightly fitted outer rings
- For bearings without radial access
- Three sets with different claws available

Ordering designation:

ABZIEHER56.020.SET

ABZIEHER56.120.SET

ABZIEHER56.220.SET



Special bearing extractor 64

- For radial bearings (deep groove ball bearings, self-aligning ball bearings as well as cylindrical roller, tapered roller and spherical roller bearings); indicate bearing manufacturer.
- For tight fit of inner ring or outer ring

Ordering example

for deep groove ball bearing 6000:

Base device **ABZIEHER64.400** +

Pincers **ABZIEHER64A.6000**

Ordering example for tapered

roller bearing pair 30203A

in X arrangement:

Base device **ABZIEHER64.400** +

Pincers **ABZIEHER64B.30203A** +

Pincers **ABZIEHER64C.30203A**



Products · Mounting/Repair

Mechanical mounting and dismounting

Mechanical extractors

Extraction device 49

- For all rolling bearing types. For extraction of complete rolling bearings or tightly fitted inner rings. The extractor and the separator device are available in five sizes with grip widths of up to 210 mm.
- Principally for cases in which the inner ring is abutted against a shoulder on the shaft without extraction slots. Good radial access to the bearing position is required.

Ordering designation:

ABZIEHER49.100.060
ABZIEHER49.100.075
ABZIEHER49.200.115
ABZIEHER49.300.150
ABZIEHER49.400.210



Internal extractor 62

- For deep groove ball bearings and angular contact ball bearings. The internal extractor set comprises nine extractors and can be used on bearings with a bore of 5 mm up to approx. 70 mm.
- For tightly fitted outer rings.
- The inner ring bore must be free.

Ordering designation (nine internal extractors with two countersupports in a rigid metal case):

ABZIEHER62.SET



The nine internal extractors can also be ordered individually.

Internal extractor PULLER.INTERNAL.SET10-100

- For standard deep groove ball bearings. The set, comprising 6 sets of extraction legs and 2 threaded spindles can be used on bores from 10 to 100 mm.
- For tightly fitted outer rings.
- No dismounting of shaft.

Ordering designation (six sets of extraction legs and two threaded spindles in a toolbox):

PULLER.INTERNAL.SET10-100

The individual parts can also be ordered individually.



Products · Mounting/Repair

Mechanical mounting and dismounting

Hydraulic extractors

Hydraulic FAG extractor PowerPull SPIDER

The hydraulic FAG extractors PowerPull SPIDER are used where higher extraction forces are required.

The ten extractor sizes have a range of extraction forces from 40 to 400 kN, covering a very wide range of possible applications.

These devices allow rolling bearings, gears, sleeves and many other shrink fitted parts to be quickly and easily dismounted. In addition, the low mass of the extractors allows for use in any position.

If necessary, greater grip depth can be achieved through the use of extra long extraction arms (available as accessories).

For protection of operators, the extractors SPIDER40 to 80 have a safety grid. All larger hydraulic extractors are supplied with a transparent, very tough safety cover. The cover can be easily placed around the workpiece or tool and secured using velcro strips.

For detailed information, see TI WL 80-56.

Overview of significant advantages

- Safety grip allows pumping while wearing industrial gloves
- Optimum operating position due to 360° rotary coupling for pump handle (separate pump with SPIDER 175 and 400)
- Pressure build-up or reduction by rotation of handle on cut-off valve
- Pressure control valve prevents overload
- Parts under mechanical load are made from high quality chromium-molybdenum steel
- Maximum possible reduction in torsional and frictional forces due to chromium plated piston made from quenched and tempered steel
- Stroke travel adjustable by means of standard adapter
- High load capacity of extraction arms and claws through manufacture as single piece
- Simple centring by spring-loaded steel cone
- “Quick” screw thread for setting of optimum grip depth
- Simple conversion to two-arm operation if insufficient space for three arms



Products · Mounting/Repair

Mechanical mounting and dismantling

Hydraulic extractors

SPIDER 40 ... 80:
Hydraulic standard extractor with integral hand pump

Compact extractor for extraction forces up to 80 kN, together with safety grid in rigid case

SPIDER 40 ... 80

Ordering designation Extractor	Extraction force kN	Grip width mm	Grip depth mm	Stroke mm	Mass kg
PULLER.HYD40	40	150	152	55	4,5
PULLER.HYD60	60	200	152 (190*)	82	4,9
PULLER.HYD80	80	250	190 (229*)	82	6,6

* Optionally with longer extraction arms, replacement parts can be ordered individually



SPIDER 100 ... 300:
Extra strong hydraulic extractor with integral hand pump

For difficult dismantling work with extraction forces up to 300 kN, with longer extraction arms on request. With accessories in rigid metal case.

SPIDER 100 ... 300

Ordering designation Extractor	Extraction force kN	Grip width mm	Grip depth mm	Stroke mm	Mass kg
PULLER.HYD100	100	280	182 (220*)	82	5,6
PULLER.HYD120	120	305	220 (259*)	82	7,6
PULLER.HYD200	200	356	259 (300*)	82	10
PULLER.HYD250	250	406	300 (375*)	110	20
PULLER.HYD300	300	540 (800*)	375 (405*)	110	25

* Optionally with longer extraction arms, replacement parts can be ordered individually



SPIDER 175 + 400:
Extra strong hydraulic extractor with separate hand pump

Extractor for restricted spaces, connected to hand pump by hydraulic hose, extraction force up to 400 kN (top of the range model)

SPIDER 175 + 400

Ordering designation Extractor	Extraction force kN	Grip width mm	Grip depth mm	Stroke mm	Mass kg
PULLER.HYD175	175	356	229 (300*)	82	15,6
PULLER.HYD400	400	800 (1200*)	405 (635*)	250	49

* Optionally with longer extraction arms, replacement parts can be ordered individually



Products · Mounting/Repair

Mechanical mounting and dismounting

Three-section extraction plates

Three-section FAG extraction plates PowerPull PULLER.TRISECTION... for hydraulic and mechanical extractors

These allow the extraction of complete bearings, tightly fitted inner rings and other components. The load capacity and extraction force are precisely matched to each other.

The SPIDER extraction claws grip directly under the screw studs of the PULLER.TRISECTION and provide uniform distribution of force. Even where parts are firmly seated, there is no tilting or bending. The high extraction forces are concentrated, for example, on the bearing inner ring. In general, the bearing and shaft remain intact and can be used again.

The PULLER.TRISECTION is proven in practical use and can be fitted under the bearing with just a few movements.

For detailed information, see TI WL 80-56.

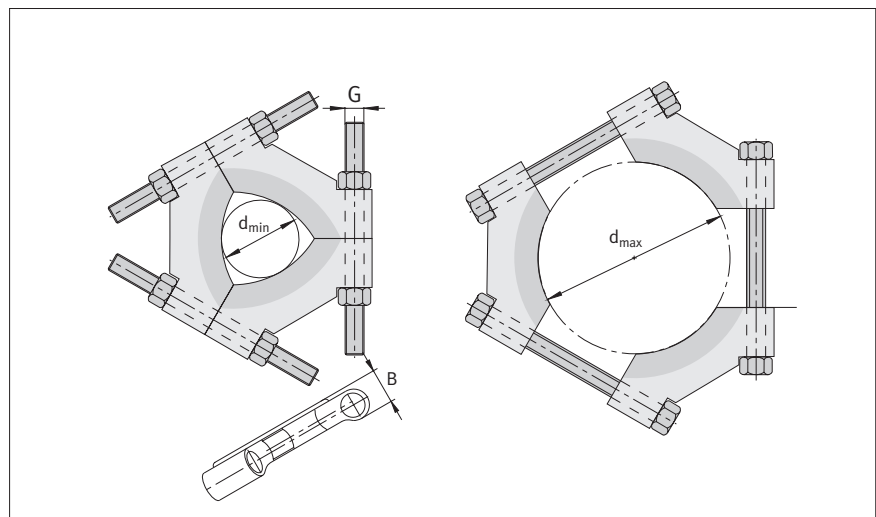

Three-section FAG extraction plates PowerPull PULLER.TRISECTION...

Ordering designation Extraction plate	Dimensions			Mass kg	Recommended for hydraulic extractor SPIDER	mechanical extractor
	d_{min} mm	d_{max}	B			
PULLER.TRISECTION ₅₀	12	50	17	0,5	–	52.085/52.130
PULLER.TRISECTION ₁₀₀	26	100	28	2,6	40/60/80/100	52.230
PULLER.TRISECTION ₁₆₀	50	160	33,5	5,8	80/100/120/175/200	52.295
PULLER.TRISECTION ₂₆₀	90	260	46,5	18,4	175/200/250/300	52.390
PULLER.TRISECTION ₃₈₀	140	380	65	50,3	250/300/400	52.640

Products · Mounting/Repair

Hydraulic mounting and dismounting

Hydraulic nuts

FAG hydraulic nuts HYD.NUT..

Hydraulic nuts HYD.NUT.. (former FAG designation: RKP) can be used to press parts with a tapered bore onto their tapered seat. Presses are mainly used if the pressing forces required cannot be applied using other devices, e.g. shaft nuts or pressure screws.

They are mainly used for:
 the mounting of rolling bearings with a tapered bore. The bearings can be seated directly on a tapered shaft, on an adapter sleeve or an extraction sleeve. If the bearing is located using an extraction sleeve or an adapter sleeve, the hydraulic nut can also be used for dismounting.
 the mounting of couplings, gears, ships' propellers etc.

For detailed information, see
 TI WL 80-57.



FAG hydraulic nuts HYD.NUT..

Ordering designation	Design	Main application
HYD.NUT50 to HYD.NUT200 HYD.NUT205 to HYD.NUT1180	With metric precision thread to DIN 13 With trapezoidal thread to DIN 13	Standardised adapter and withdrawal sleeves with metric dimensions
HYD.NUT90INCH to HYD.NUT530INCH	With inch size thread to ABMA Standards for Mounting Accessories, Section 8, Locknut Series N-00	Sleeves with inch dimensions
HYD.NUT100HEAVY to HYD.NUT900HEAVY	Reinforced design with smooth bore	For high mounting forces, e.g. in shipbuilding
HYD.NUT.DISPLACE.GAUGE	Displacement gauge for HYD.NUT (see also page 20)	Where radial internal clearance cannot be measured using feeler gauge due to poor accessibility

Products · Mounting/Repair Hydraulic mounting and dismounting

FAG displacement distance gauge for hydraulic nuts

FAG displacement distance gauge for hydraulic nuts

If the radial internal clearance cannot be measured with a feeler gauge due to poor accessibility, the axial displacement of the bearing on the tapered seat can be measured. This can be achieved by means of a gauge screw mounted to the end face of the hydraulic nut.

If the axial threaded connector hole G $\frac{1}{4}$ of the hydraulic nut is taken up by the pump, the second axial hole can be used for the displacement distance gauge. The bearing is first placed in its starting position. The oil pressure required is dependent on the bearing size and the number of displacement surfaces and is given in the user manual. A hand pump set with a manometer must be used, see page 25. The dial gauge is set to zero and the bearing is moved by pumping until the specified displacement is achieved. The user can determine which of the metering needles supplied should be used from the comprehensive user manual included with each gauge.

Ordering designation:

HYD.NUT.DISPLACE.GAUGE

(former FAG designation: RKP.MG)
1 displacement distance gauge with dial gauge, 6 metering needles and seals in case

For detailed information, see
TI WL 80-57.



Products · Mounting/Repair

Hydraulic mounting and dismounting

Mounting Manager

FAG Mounting Manager

The FAG computer program **MOUNTING MANAGER** is a user-friendly aid for ensuring the correct mounting of bearings with tapered bore and offers the following options:

- it shows various mechanical and hydraulic mounting methods
- it calculates the data required for mounting in relation to reduction in radial internal clearance, displacement and start pressure
- it gives useful mounting advice
- and it generates a list of the accessories and tools required

Further information on mounting and dismounting of bearings is offered in the integrated library containing appropriate publications, Technical Information documents etc. and the Rolling Bearing Learning System (WLS).

Calculation possibilities for mounting methods:

Bearings with a tapered bore are mounted either directly on the tapered shaft or journal, or by means of an adapter sleeve or extraction sleeve on the cylindrical shaft. The internal clearance is set either by conventional means using feeler gauges or by means of the axial displacement.

a) Mounting of bearings with tapered bore by measurement of the axial displacement

The bearing is placed in its starting position on the tapered bearing seat with a hydraulic nut. The required starting pressure defined for each individual bearing is set in the hydraulic nut by means of the digital manometer. The dial gauge mounted on the hydraulic nut is used to measure the axial displacement until the final position is reached on the tapered seat.

This mounting method:

- gives considerably shorter and simpler mounting
- offers very high security and accuracy
- allows the correct mounting of sealed bearings

b) Mounting of bearings with tapered bore by measurement of the reduction in radial internal clearance

When the bearing is pushed onto the tapered seat, the inner ring is expanded and the radial internal clearance is thereby reduced. This reduction in radial internal clearance is valid as a measure of the firm seating of the bearing. It is measured by means of a feeler gauge.

The FAG Mounting Manager is available on CD-ROM.

Ordering designation:
CD-MM 1.0







Products · Mounting/Repair

Hydraulic mounting and dismantling

Overview of pressure generation devices

Overview of pressure generation devices





	Pressure device		Hand pump set		
	Oil injector		Single stage	Twin stage	
	OILINJECTOR1600	OILINJECTOR2500	PUMP1000.0,7L	PUMP1000.4L	PUMP1600.4L
					
Oil container volume [l]	0,027	0,008	0,7	4	4
Connector	G ³ / ₄	G ³ / ₈	G ¹ / ₄	G ¹ / ₄	G ¹ / ₄
Max. oil pressure [bar]	1600	2500	1000	1000	1600
(psi)	23200	36250	14500	14500	23200
Application	Mounting and dismantling of bearings with tapered bore. Press fits up to approx. 80 N/mm ² contact pressure.	Mounting and dismantling of bearings with tapered bore. Press fits up to approx. 125 N/mm ² contact pressure.	Mounting and dismantling of rolling bearings. Mounting of press fits up to approx. 50 N/mm ² contact pressure. For driving hydraulic nuts up to HYD.NUT395/ HYD.NUT300HEAVY	Mounting and dismantling of rolling bearings. Mounting of press fits up to approx. 50 N/mm ² contact pressure, e.g. of ships' propellers. For driving hydraulic nuts up to HYD.NUT800	Mounting and dismantling of rolling bearings. Mounting of press fits up to approx. 80 N/mm ² contact pressure, e.g. of rudder spindles and rudder blades.
Max. shaft ø [mm]	150	80	250	Unlimited	Unlimited

Products · Mounting/Repair

Hydraulic mounting and dismantling

Overview of pressure generation devices

Overview of pressure generation devices

	Pressure device Hand pump set Twin stage PUMP2500.4L	High pressure pump PUMP4000.0,2L	High pressure pump set PUMP2500.0,2L.SET	Hydraulic unit Compressed air AGGREGATE.P1000/2500	Electric AGGREGATE.E700
					
Oil container volume [l]	4	0,2	0,2	13	10
Connector	G ¹ / ₄ (direct)	G ³ / ₄ (direct)	G ¹ / ₄ with high pressure hose	G ¹ / ₄	G ¹ / ₄
Max. oil pressure [bar] (psi)	2500 36250	4000 58000	2500 36250	2500 36250	700 10150
Application	Mounting and dismantling of bearings. Mounting of press fits up to approx. 125 N/mm ² contact pressure, e.g. of gears and couplings.	For press fits with high contact pressure (> 100 N/mm ²). Dismounting of bearings with cylindrical bore. Flow rate and oil reservoir are small.	For press fits with high contact pressure (> 100 N/mm ²). Dismounting of bearings with cylindrical bore. Flow rate and oil reservoir are small.	Mounting of shaft couplings and press fits, gears etc. by the hydraulic method. Contact pressure up to 100 N/mm ² .	For driving large hydraulic nuts up to HYD.NUT1180. Mounting of large press fits: ship shaft couplings, ships' propellers, gears, contact pressure up to 50 N/mm ² .
Max. shaft ø [mm]	Unlimited	Unlimited for rolling bearings up to d= 250 mm	Unlimited	Unlimited	Unlimited

Products · Mounting/Repair

Hydraulic mounting and dismounting

Oil injectors

FAG oil injectors

Oil injectors have a small flow rate; they can be used in the hydraulic method for the dismounting of rolling bearings and other press fits with direct seating on tapered shafts, e.g. in machine tools for FAG cylindrical roller bearings NNU49SK, NN30ASK, N10K, N19K.

The OILINJECTOR2500 can be used for shaft diameters up to 80 mm, the OILINJECTOR1600 up to 150 mm.

Conventional O rings can be used as replacement seals: OR6×1,5 (for OILINJECTOR2500), OR10×2,0 (for OILINJECTOR1600).

For detailed information, see TI WL 80-50.



FAG oil injectors					
Oil injector	Valve nipple	Connector	Oil volume	Max. oil pressure	Mass ≈
Ordering designation		G	cm ³	bar	kg
OILINJECTOR2500 (107640)	OILINJECTOR2500.VALVE (107642)	G ³ / ₈	8	2500	0,91
OILINJECTOR1600 (107641)	OILINJECTOR1600.VALVE (107643)	G ³ / ₄	27	1600	2,18

The oil injector can be refilled with oil without losses by connecting the valve nipple to the oil injector. In this case, the oil injector is ordered with a valve nipple.

Ordering designation for OILINJECTOR2500 + OILINJECTOR2500.VALVE: **OILINJECTOR2500.SET**,

Ordering designation for OILINJECTOR1600 + OILINJECTOR1600.VALVE: **OILINJECTOR1600.SET**

Products · Mounting/Repair

Hydraulic mounting and dismounting

Hand pump sets

FAG hand pump sets

FAG offers a hand pump set with a single stage pump and three hand pump sets with a twin stage pump. The twin-stage pumps have a high flow rate in the low pressure range (up to 50 bar) and then switch

automatically to the high pressure stage. This generates a high work rate. Where there is an increased oil requirement, the twin stage pumps are available with an 8 litre oil container (suffix .8L). For those cases in which the type of installation of the adapter or

extraction sleeve requires a separate oil supply, FAG supplies upon request a two-way valve (suffix .D).

For detailed information, see TI WL 80-50.



PUMP1000.0,7L.DIGI



PUMP2500.8L.D

FAG hand pump sets (overview of ordering designations)

Pump	Hand pump set Base design	With 8 litre oil container	With distributor	With 8 litre oil container and distributor
Single stage 1000 bar	PUMP1000.0,7L*			
Twin stage 1000 bar	PUMP1000.4L*	PUMP1000.8L*	PUMP1000.4L.D	PUMP1000.8L.D
1600 bar	PUMP1600.4L	PUMP1600.8L	PUMP1600.4L.D	PUMP1600.8L.D
2500 bar	PUMP2500.4L	PUMP2500.8L	PUMP2500.4L.D	PUMP2500.8L.D

* The 1000 bar pumps with one connector are also available with a digital manometer.

Ordering example: **PUMP1000.0,7L.DIGI**

Products · Mounting/Repair

Hydraulic mounting and dismounting

High pressure pump · High pressure pump sets

FAG high pressure pump PUMP4000.0,2L

The high pressure pump is suitable for mounting and dismounting of rolling bearings for shaft diameters up to 250 mm. Since it generates pressures up to 4000 bar, the pump can be used to expand heavy shaft couplings and gears by the hydraulic method. The pump is connected directly or via thick-walled adapters.

The high pressure pump can also be connected via a pump holder (with or without a manometer) and a 2 metre flexible high pressure hose (permissible oil pressure 2500 bar). The pump must always be operated with a manometer.

For detailed information, see
TI WL 80-50.

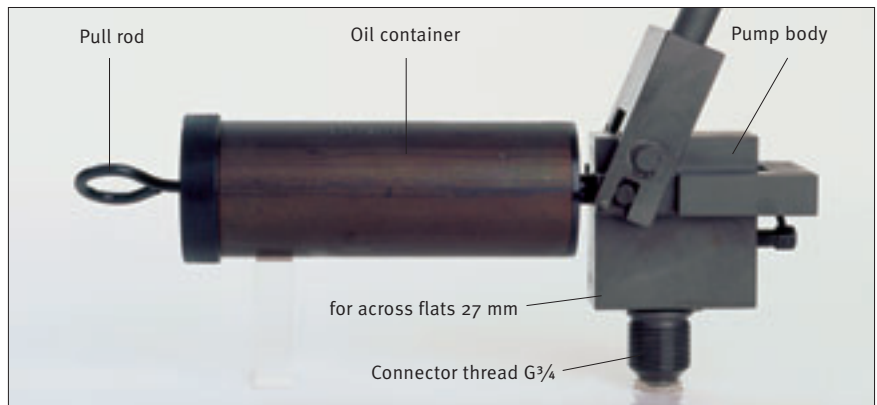

FAG high pressure pump PUMP4000.0,2L

High pressure pump	Connector	Oil container volume	Flow rate	Max. oil pressure	Mass ≈
Ordering designation		l	cm ² /stroke	bar	kg
PUMP4000.0,2L ^{*)}	G ³ / ₄	0,2	0,3	4000	3,8
comprising					
PUMP4000.0,2L.BODY (pump body)					
PUMP4000.0,2L.TANK (oil container)					
^{*)} formerly 120109					

FAG high pressure pump sets

In order to make it easier to select the right device, FAG supplies complete sets in storage cases.



FAG high pressure pump set PUMP2500.0,2L.SET

For detailed information, see
TI WL 80-50.

FAG high pressure pump set PUMP2500.0,2L.SET with manometer up to 2500 bar

Included in delivery:

- | | |
|------------------------------------|----------------------|
| 1 high pressure pump PUMP4000.0,2L | 1 manometer |
| 1 Pump holder | 1 high pressure hose |
| 3 reduction nipples | 1 storage case |

Ordering designation for set: **PUMP2500.0,2L.SET**

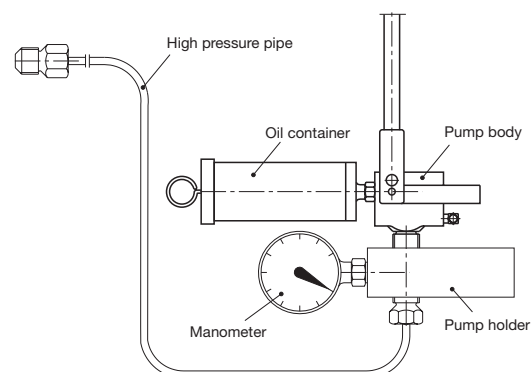

Products · Mounting/Repair

Hydraulic mounting and dismantling

Hydraulic systems and units

Compressed air driven FAG hydraulic unit

The compressed air driven FAG hydraulic unit AGGREGATE.P1000/2500 is mobile and comprises a 13 litre oil container made from light metal and two pumps (1000 bar and 2500 bar). FAG supplies designs for other operating pressures by agreement. The 2500 bar pump has two separately controllable outputs and is suitable as a pressure device for expanding shaft couplings

and gears by the hydraulic method. The 1000 bar pump can charge a hydraulic nut at the same time. The pump is suitable for press fits with contact pressures up to 100 N/mm².

Included in delivery:
Base unit, ready-to-use,
incl. 1 manometer, 0 to 1000 bar,
1 manometer 0 to 2500 bar,
3 high pressure hoses, 2500 bar,
2 metres

Compressed air driven FAG hydraulic unit

Hydraulic unit	Oil container volume	Max. oil pressure	Mass
Ordering designation	l	bar	≈ kg
AGGREGATE.P1000/2500	13	1000 or 2500	40 (without oil)

Electrically driven FAG hydraulic unit

These units are suitable for charging large hydraulic nuts and mounting of large press fits such as ship shaft couplings, ships' propellers and gears (contact pressure up to 50 N/mm²). Electrical connection: plug, voltage 400 V at 50 Hz. Other voltages and frequencies by agreement.

Included in delivery:
Base unit, ready-to-use,
incl. 1 manometer, 0 to 1000 bar,
1 high pressure hose, 1000 bar,
2 metres, 1 pressure control valve

Electrically driven FAG hydraulic unit

Hydraulic unit	Oil container volume (suction quantity)	Oil volume flow	Max. oil pressure	Motor rating	Mass
Ordering designation	l	l/min	bar	kW	≈ kg
AGGREGATE.E700	10	0,9	700	1,1	40 (with oil)

Mobile FAG hydraulic unit for batch mounting

The mobile unit has a valve-controlled, double direction pressure cylinder (pressure force 700 kN, stroke 215 mm) driven by a motor pump. The height position of the cylinder can be varied between 290 and 690 mm by means of a lifting cylinder and rocker. Accessories such as guide bushes, mounting sleeves, traction and pressure spindles and drawing frames must be ordered according

to the individual application. When making enquiries or placing orders, information on the bearing type and power connection as well as installation drawings (shaft, housing, additional parts) are required. This unit is principally used for the mounting and dismantling of FAG TAROL wheelset bearings (see also FAG TI WL 80-50).

Ordering designation:
TAROL.MOUNTING.AGGREGATE
(MHU.TAROL)



Products · Mounting/Repair

Hydraulic mounting and dismantling

Connectors, accessories

FAG adapters and reduction nipples

Adapters and reduction nipples are matched to the threads of high pressure hoses and pressure pipes. Adapters and reduction nipples of type A (with sealing ring) are suitable for oil pressures up to 800 bar.

Type B (with blade sealing) is suitable for oil pressures up to 2500 bar.

Other adapters and reduction nipples can be supplied by agreement.

For detailed information, see TI WL 80-50.

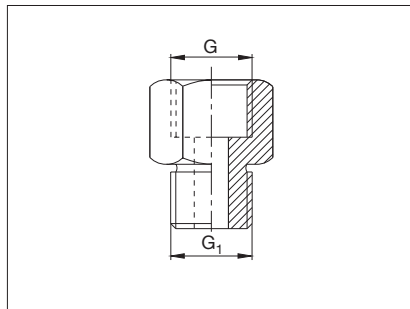

Type A (with sealing ring)

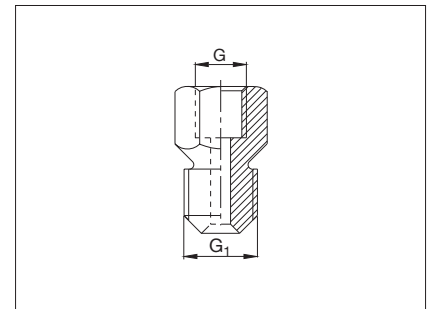

Type B (with blade sealing)



Reduction nipple

Reduction nipple $G > G_1/G < G_1$
Ordering designation

PUMP.NIPPLE.A.G¹/₄-G¹/₈

PUMP.NIPPLE.B.G¹/₄-G¹/₈

PUMP.NIPPLE.A.G¹/₄-G¹/₂

PUMP.NIPPLE.B.G¹/₄-G¹/₂

PUMP.NIPPLE.A.G¹/₄-G³/₄

PUMP.NIPPLE.B.G¹/₄-G³/₄

PUMP.NIPPLE.A.G¹/₄-M14

PUMP.NIPPLE.B.G¹/₄-M14

PUMP.NIPPLE.A.G¹/₄-M18×1,5

PUMP.NIPPLE.A.G³/₈-G¹/₄

PUMP.NIPPLE.B.G³/₈-G¹/₄

PUMP.NIPPLE.A.G³/₄-G¹/₈

PUMP.NIPPLE.B.G³/₄-G¹/₈

PUMP.NIPPLE.A.G³/₄-G¹/₄

PUMP.NIPPLE.B.G³/₄-G¹/₄

Reduction nipple

Reduction nipple $G > G_1/G < G_1$
Ordering designation

PUMP.NIPPLE.A.G³/₄-G³/₈

PUMP.NIPPLE.B.G³/₄-G³/₈

PUMP.NIPPLE.A.M18×1,5-G¹/₄

PUMP.NIPPLE.A.M18×1,5-G³/₈

PUMP.NIPPLE.A.M18×1,5-G³/₄

Adapter

Adapter $G_1 = G$
Ordering designation

PUMP.ADAPTER.A.G¹/₄

PUMP.ADAPTER.B.G¹/₄

PUMP.ADAPTER.A.G³/₄

PUMP.ADAPTER.B.G³/₄

Products · Mounting/Repair

Hydraulic mounting and dismounting

Connectors, accessories

FAG pump holder

FAG pump holder

Pump holder	Ordering designation	Mass ≈ kg
Without connector for manometer	PUMP.HOLDER.2 (118543/2)	1,95
With connector G $\frac{1}{2}$ for manometer	PUMP.HOLDER.3 (118543/2A)	1,95



FAG manometers

When selecting a manometer, pay attention to the max. operating pressure.



FAG manometers

Manometer	Connector thread	Pressure display	Diameter	Mass
Ordering designation	(Former ordering designation)	bar	≈ mm	≈ kg
PUMP1000.MANO.DIGI	–	0 – 1000	73	0,4
PUMP1000.MANO.G$\frac{1}{2}$	(124830)	0 – 1000	100	0,8
PUMP1600.MANO.G$\frac{1}{2}$	(130594)	0 – 1600	100	1,5
PUMP2500.MANO.G$\frac{1}{2}$	(133315)	0 – 2500	160	1,7

For detailed information, see TI WL 80-50.

Products · Mounting/Repair Hydraulic mounting and dismantling

Connectors, accessories

FAG high pressure pipes for high pressure pumps, sheathed in PVC hose (max. permissible pressure of 2500 bar should be monitored by manometer)



FAG high pressure pipes

High pressure pipe	(Former ordering designation)	Consumer collector	Mass ≈ kg
Ordering designation			
PUMP.PIPE.G $\frac{1}{4}$	(164641)	G $\frac{1}{4}$	0,6
PUMP.PIPE.G $\frac{3}{8}$	(123076)	G $\frac{3}{8}$	0,6
PUMP.PIPE.G $\frac{1}{2}$	(128167)	G $\frac{1}{2}$	0,6
PUMP.PIPE.G $\frac{3}{4}$	(120386)	G $\frac{3}{4}$	0,8

The connector for the pump holder is G $\frac{3}{4}$.

For other consumer collectors, a suitable reduction nipple must be used in addition.

For detailed information, see TI WL 80-50.

FAG sleeve connectors for adapter and extraction sleeves (up to 800 bar)

(special lengths available by agreement)



FAG sleeve connectors

Connector	(Former ordering designation)	Connector thread	Mass ≈ kg
Ordering designation			
PUMP.SLEEVE.CONNECTOR.M6	(118549A-M6)	M6	0,22
PUMP.SLEEVE.CONNECTOR.M8	(118549A-M8)	M8	0,245
PUMP.SLEEVE.CONNECTOR.G $\frac{1}{8}$	(118549A-G $\frac{1}{8}$)	G $\frac{1}{8}$	0,285
PUMP.SLEEVE.CONNECTOR.G $\frac{1}{4}$	(118549A-G $\frac{1}{4}$)	G $\frac{1}{4}$	0,42

The connector for the hand pump set is G $\frac{1}{4}$.

For detailed information, see TI WL 80-50.

Products · Mounting/Repair

Thermal mounting and dismounting

Electric heating plate · Induction heating devices

FAG electric heating plate HEATER.PLATE

Where tight fits are to be achieved on cylindrical bearing seats, it is advisable to heat bearings for mounting. Sufficient expansion can be achieved at 80 to 100 °C. When heating the bearings, the temperature must be precisely monitored, for example by using the FAG temperature measuring instrument TEMP.MG. It must not under any circumstances rise above 120 °C, in order to prevent changes to the structure and hardness. Rolling bearings can be heated on a temperature-controlled FAG heating plate HEATER.PLATE. The bearing must be covered with sheet metal and turned over several times in order to ensure uniform heating. The heating plates can be used to heat not only rolling bearings (maximum temperature 120 °C!) but also labyrinth rings, shrink fit rings and sealing rings.

Dimensions (B×T×H):
390×270×156 mm
Power: max. 1500 W
at 230 V/50 Hz *
Temperature control:
continuously variable from
50 to 200 °C

Ordering designation:
HEATER.PLATE

* Also available with 115 V/60 Hz



For detailed information see
TI WL 80-54.

By agreement, FAG also supplies heating plates for heating parts up to 300 °C. This design is used, for example, for heating FAG aluminium heating rings (see page 34).

FAG induction heating devices

Many rolling bearings and other rotationally symmetrical parts made from steel have tight fits on the shaft. In particular, larger parts can be mounted more easily if they are heated first (rolling bearings must not be heated to more than 120 °C).

Rapid and clean induction heating is superior to the conventional methods. It is therefore particularly suitable for batch mounting. The devices can be used for heating complete bearings, rings for cylindrical roller or needle roller bearings and rotationally symmetrical steel parts such as labyrinth rings, roll couplings, tyres etc.

Advantages

- Rapid, energy-efficient operation
- Suitable for rolling bearings and other ring-shaped steel parts
- Extremely safe operation
- Environmentally friendly, oil-free (no disposal required)
- Uniform, controlled heating
- Easy to use
- Automatic demagnetisation
- High cost-effectiveness through selection of the most suitable size of device for the particular application

For the mounting of workpieces up to 300 kg mass, FAG supplies five table-top heating devices Power-Therm HEATER10 to 300 suitable for mobile and/or stationary use. For workpieces up to 3000 kg mass, we recommend the heavy duty standalone devices AWG25, AWG40 and AWG100.

For detailed information, see
TI WL 80-54.

Products · Mounting/Repair

Thermal mounting and dismounting

Induction heating devices

Overview of induction heating devices

Heating device
HEATER10



HEATER20



HEATER35



HEATER150



Power consumption

max.	2,2 kVA	3,5 kVA	3,5 kVA	12,8 kVA
Voltage/frequency*	230 V/50 Hz	230 V/50 Hz	230 V/50 Hz	400 V/50 Hz
Current	10 A	16 A	16 A	32 A

Mass	7 kg	17 kg	31 kg	51 kg
Length	230 mm	345 mm	420 mm	505 mm
Width	200 mm	200 mm	260 mm	260 mm
Height	240 mm	240 mm	360 mm	440 mm

Ledges (included in delivery)	10×10×25 mm	14×14×200 mm	50×50×280 mm	70×70×350 mm
	30×30×40 mm	25×25×200 mm		
	46×40×55 mm	40×40×200 mm		

Clear width	65 mm	120 mm	180 mm	210 mm
Clear height	120 mm	100 mm	160 mm	215 mm

Accessory ledges	7×7×105 mm	7×7×200 mm	10×10×280 mm	14×14×350 mm
	10×10×105 mm	10×10×200 mm	14×14×280 mm	20×20×350 mm
		30×30×200 mm	25×25×280 mm	30×30×350 mm
			30×30×280 mm	40×40×350 mm
			40×40×280 mm	50×50×350 mm
				60×60×350 mm

Rolling bearing / workpiece

Min. bore**	15 mm	20 (10) mm	70 (15) mm	100 (20) mm
Max. width	65 mm	120 mm	180 mm	210 mm
Max. mass	10 kg	20 kg	35 kg	150 kg (horizontal only)

* FAG also supplies induction heating devices for other voltages and frequencies.

** Values in brackets refer to accessory ledges

Products · Mounting/Repair

Thermal mounting and dismounting

Induction heating devices

Overview of induction heating devices

Heating device
HEATER300 ***



AWG25



AWG40



AWG100



Power consumption

max.	12,8 kVA	25 kVA	40 kVA	100 kVA
Voltage/frequency*	400 V/50 Hz	400 V/50 Hz	400 V/50 Hz	400 V/50 Hz
Current	32 A	63 A	100 A	250 A

Mass	125 kg	350 kg	600 kg	2000 kg
Length	700 mm	1280 mm	1800 mm	3000 mm
Width	500 mm	500 mm	600 mm	1000 mm
Height	900 mm	1250 mm	1400 mm	1800 mm

Ledges (included in delivery)	80×80×490 mm	100×100×700 mm	150×150×850 mm	200×200×1300 mm
----------------------------------	--------------	----------------	----------------	-----------------

Clear width	390 mm	390 mm	600 mm	800 mm
Clear height	300 mm	430 mm	450 mm	800 mm

Accessory ledges	20×20×490 mm	30×30×700 mm	60×60×850 mm	100×100×1300 mm
	30×30×490 mm	40×40×700 mm	80×80×850 mm	150×150×1300 mm
	40×40×490 mm	60×60×700 mm	100×100×850 mm	
	50×50×490 mm	80×80×700 mm		
	60×60×490 mm			
	70×70×490 mm			

Rolling bearing / workpiece

Min. bore**	115 (30) mm	145 (45) mm	220 (85) mm	290 (145) mm
Max. width	390 mm	390 mm	600 mm	800 mm
Max. mass	300 kg (horizontal only)	600 kg	1200 kg	3000 kg

*** HEATER300 can be converted to a mobile unit. Ordering designation for the trolley required: HEATER300.TROLLEY

FAG also supplies special heating devices with even higher power ratings for very heavy

workpieces or for automation in special process operations.

Products · Mounting/Repair

Thermal mounting and dismantling

Heating rings · Heat conducting paste

FAG heating rings

Heating rings are suitable for dismantling the inner rings of cylindrical roller and needle roller bearings without ribs and inner rings with one rib. Heating rings are particularly advantageous for the occasional extraction of small and medium-sized bearing rings (bore diameter 50 to 200 mm). Depending on the size of the ring, heating takes between 5 and 30 seconds. The heating rings are made from light metal. They have a radial slot. They are easy to handle due to the heat-insulated handles.

Heating rings are heated to between 200 and 300 °C by means of an electric heating plate. The cylindrical outside surface of the bearing inner ring must be coated with a silicone-free heat conducting paste (HEATING.RING.PASTE). This provides optimum heat transfer. The bearing ring must be removed from the heating ring immediately

after extraction in order to prevent overheating.

Each bearing size requires a special heating ring. By agreement, FAG supplies these heating rings made from a special aluminium alloy. In order to prepare a quotation, we require the following information:

1. Bearing designation or ring dimensions,
2. Drawing of mounting position stating fits.
3. Approximate number of parts to be extracted per day

Recommended FAG accessories

- Electric heating plate for temperatures up to 300 °C (by agreement)
- Temperature measuring instrument **TEMP.MG** (see page 62)
- Gloves **HANDSCHUH2**
- Heat conducting paste (see below) **HEATING.RING.PASTE** (20 ml included in delivery)

Ordering examples for heating rings

HEATING.RING320E

(for the inner ring of a cylindrical roller bearing NU320E, NJ320E etc.)

HEATING.RING2317E

(for the inner ring of a cylindrical roller bearing NU2317E, NJ2317E etc.)

For detailed information, see TI WL 80-58.



FAG heat conducting paste HEATING.RING.PASTE

The silicone-free heat conducting paste HEATING.RING.PASTE is used as an aid in the dismantling of bearing inner rings by means of heating rings.

The cylindrical outside surface of the bearing inner ring is coated with the heat conducting paste before extraction in order to achieve optimum heat transfer from

the heating ring to the bearing inner ring.

(disposable syringe containing 20 ml silicone-free heat conducting paste):

HEATING.RING.PASTE.20ML

For detailed information, see TI WL 80-58.



Products · Mounting/Repair

Thermal mounting and dismounting

Electric induction heating devices (coils)

Electric induction heating devices (coils)

Electric induction heating devices are suitable for the dismounting of inner rings on medium-sized and large cylindrical roller and needle roller bearings (bore diameter 90 mm and larger).

They can also be used to heat labyrinth rings, couplings, ring rolls and other rotationally symmetrical parts.

Heating devices with low voltage

This design comprises an induction coil and a transformer.

The coil runs on safe low voltage and is water-cooled.

This allows continuous heating, which is particularly suitable for batch mounting. Due to the lightweight construction, these devices are easy to handle.

Each bearing size requires a special coil.

The coil is connected to a mobile transformer that can be designed for any mains voltage. The voltage for the coil is adjustable to a value between 20 and 40 V.

The transformers for the induction coils are available from FAG in six different power steps.

The largest transformer and the corresponding coil can be used to heat inner rings up to a maximum mass of 1200 kg to the required dismounting temperature of 80 ... 120 °C (in the case of couplings, the maximum mass is 600 kg).

Ordering example for bearing inner rings 120×150×144 mm:

COIL152/145LOW.1 (coil)

COIL.TRANSFORMER45.400V.50HZ (transformer)

Heating devices with mains voltage

In addition to coils for low voltage, FAG also supplies coils for mains voltage (with a switch box or foot switch). This economical alternative without water cooling is used for sporadic dismounting (where batch dismounting is not required).

Information required for quotation

FAG induction heating devices are always produced as one-off items. In order to prepare a quotation, we require the following information:

1. Exact **designation** of the bearing or **dimensions** of the parts to be extracted
2. Width of the **intermediate ring**, if available
3. The **mains voltage and frequency** present at the mounting location

For detailed information, see TI WL 80-58.



Heating device for low voltage with transformer for dismounting the inner rings of cylindrical roller bearings

Products · Mounting/Repair Measurement and inspection

Feeler gauges · Taper gauges

FAG feeler gauges FEELER.GAUGE100 and FEELER.GAUGE300

Feeler gauges are used to measure the radial internal clearance, especially for mounting on tapered

shaft seats and on adapter and extraction sleeves.

FAG feeler gauges FEELER.GAUGE100 and FEELER.GAUGE300

Ordering designation	Feeler length mm	Feeler thickness mm		
FEELER.GAUGE100	100	0,03	0,08	0,14
		0,04	0,09	0,16
		0,05	0,10	0,18
		0,06	0,12	0,20
		0,07		
FEELER.GAUGE300	300	0,03	0,12	0,20
		0,04	0,13	0,25
		0,05	0,14	0,30
		0,06	0,15	0,35
		0,07	0,16	0,40
		0,08	0,17	0,45
		0,09	0,18	0,50
		0,10	0,19	



FAG feeler gauges FEELER.GAUGE100 and FEELER.GAUGE300

Taper gauges

When a bearing with a tapered bore is seated directly on the shaft, the tapered bearing seat must be

precisely machined such that the fit surfaces match precisely. FAG supplies various gauges for measuring the taper. Most bearings with a tapered bore have a

taper 1:12. Only spherical roller bearings of series 240 and 241 have a taper 1:30.

FAG taper ring gauge

The simplest means of measuring tapered shaft seats of small bearings is the taper ring gauge. By application of bluing material, it can be determined whether the shaft and ring gauge match. Corrections are made until the ring gauge fits the shaft over its whole width. The inner rings of the bearings are not suitable as ring gauges because their walls are too thin and could be damaged. FAG supplies taper ring gauges for taper diameters from 30 to 240 mm.

Ordering designation (example):

KLR20

Taper ring gauge for bearings of 100 mm bore, e.g. for double row cylindrical roller bearings NN3020ASK or NNU4920SK.

FAG taper ring gauge

Taper ring gauge	Taper diameter mm
Ordering designation	mm
KLR06...KLR48	30 ... 240



Products · Mounting/Repair Measurement and inspection

Taper gauges

FAG taper gauge MGK 9205

for the inspection of large tapered shaft studs (taper 1:12 or 1:30)

Measurement principle of taper gauge MGK 9205: When measuring tapered studs of large diameter, a master can be used in which the upper and lower edge form an angle, the taper angle of the stud = 2α . If the upper edge of the master is parallel to the line diametrically opposed to the master, the taper angle is acceptable.

It is further required that the taper is in a defined ratio to a datum surface, e.g. to the side face of a roll barrel.

FAG taper gauges MGK 9205 are available in several sizes. The delivery of individual gauges, and also of complete sets, always includes two magnets. Delivery also includes belts for fixing the gauge in positions other than on the upper side of the stud.

Ordering examples for gauge sets (each with two saddles and five masters):

MGK9205.12.SET (taper 1:12)

MGK9205.30.SET (taper 1:30)

See also TI WL 80-70.



FAG taper gauge MGK 9205

FAG taper gauge MGK 133

for external tapers 1:12 and 1:30 and 27 to 205 mm taper diameter.

The taper gauge MGK 133 rests on the taper with four hardened and polished support bolts. The position of the gauge on the taper is defined by these bolts and one stop. The stop can be attached to either the front or back of the gauge. The gauge contains two movable measuring brackets, one of which is in contact with the smaller taper diameter while the

other, at a fixed distance, is in contact with the larger taper diameter.

The deviation of the taper diameter from the nominal value is displayed in both measurement planes by a precision indicator.

The reproducibility of the measurement results is less than $1 \mu\text{m}$. The gauge is set using a gauge taper (available by agreement).



FAG taper gauge MGK 133

Products · Mounting/Repair Measurement and inspection

Taper gauges · Snap gauge

FAG taper gauge MGK 132
for external tapers with 0° to 6°
taper angle and 90 to 510 mm taper
diameter

With the taper gauge MGK 132, the reproducibility of the measurement results is within $1\ \mu\text{m}$. The MGK 132 rests on the workpiece with four hardened, ground and lapped ledges. The ledges form an angle of 90° . A stop on the front or rear precisely defines the position of the gauge. Between the support ledges, the measurement slide runs on

preloaded roller bearings. A dial gauge fixed in the housing acts against the measurement slide and indicates the deviation of the taper diameter from the nominal value. A precision indicator is fixed to the measurement slide. Its blade-shaped tip is in contact with the workpiece and measures the deviation of the taper from the nominal value. The gauge is set using a gauge taper (available by agreement).

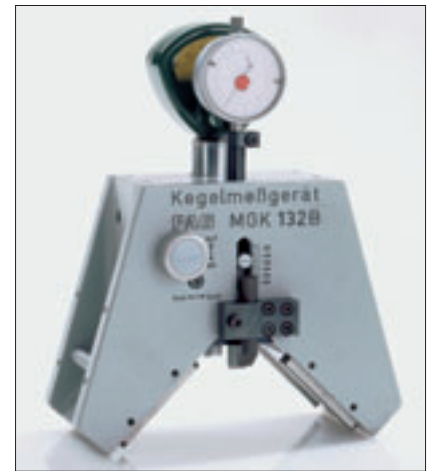

FAG taper gauge MGK 132

FAG snap gauge
SNAP.GAUGE...-...

for inspecting the diameter of cylindrical shafts and workpieces of all types, directly on the machine tool and for setting the enveloping circle gauge MGI 21 (see page 39)

The actual dimension of the workpiece can be determined precisely.

The snap gauge functions as a comparator gauge. Its setting is checked using shims. FAG supplies the shims required for each diameter.

Available snap gauges

Ordering designation	Range mm
SNAP.GAUGE30-60	30–60
SNAP.GAUGE60-100	60–100
SNAP.GAUGE100-150	100–150
SNAP.GAUGE150-200	150–200
SNAP.GAUGE200-250	200–250
SNAP.GAUGE250-300	250–300

Ordering example
for shaft diameter 120 mm:

SNAP.GAUGE100-150
(snap gauge)
SNAP.GAUGE.MASTER.DISK120
(shim)



FAG snap gauge

Products · Mounting/Repair Measurement and inspection

Enveloping circle gauges

FAG enveloping circle gauge MGI 21 for setting the radial internal clearance of cylindrical roller bearings NNU4920K to NNU4964K and NNU4920 to NNU4964

Bearings of bore diameter 100 to 320 mm have removable inner rings.

In the FAG enveloping circle gauge MGI 21, the internal enveloping circle of the roller and cage assembly is measured by two hardened and precision ground surfaces, one of which is movable. After mounting of the outer ring, the gauge is set to the internal enveloping circle of the roller and

cage assembly. This dimension is measured using a snap gauge, for example the SNAP.GAUGE...-... (see page 38).

It is then possible to set the inner ring to the diameter that gives the required radial internal clearance. Bearings with a tapered bore are slid onto the tapered seat of the shaft.

For bearings with a cylindrical bore, preground inner rings are used (suffix F12) that are finish ground to the required raceway diameter.

Ordering example for NNU4920:
MGI21.4920



FAG enveloping circle gauge MGI 21 for setting radial internal clearance or preload of cylindrical roller bearings with removable inner ring

FAG enveloping circle gauge MGI 31 for setting the radial internal clearance of cylindrical roller bearings NN3006K to NN3038K and N1006K to N1048K

Bearings with a tapered bore have removable outer rings.

The gauge is used to precisely set the radial internal clearance or preload of the cylindrical roller bearings.

The raceway diameter of the mounted outer ring is measured using a conventional internal gauge.

This dimension is transferred to the two hardened and precision ground measuring surfaces of the enveloping circle gauge.

The tapered shaft with the premounted inner ring and roller and cage assembly can then be inserted in the gauge. The shaft is moved axially by the hydraulic method until the precision indicator shows the required radial internal clearance or preload.

Ordering example for NN3006K:
MGA31.3006



FAG enveloping circle gauge MGA 31 for setting radial internal clearance of cylindrical roller bearings with removable inner ring

Products · Mounting/Repair Accessories

Transport and mounting tool

FAG transport and mounting tool

BEARING.MATE from FAG is an accessory for the secure, rapid and easy handling of medium-sized and large rolling bearings. It can also be used where bearings are heated prior to mounting.

The tool comprises two handles and two steel strips.

Turning the handles clamps the steel strips firmly on the outer ring of the rolling bearing.

The compact packaging also includes two brackets. These are used on spherical roller bearings and self-aligning ball bearings in order to prevent tilting of the inner rings.

The tool and bearing are carried either by two people or a crane. If two carrying slings are used, the rolling bearing can be rotated to any position when transported by crane. During heating on an induction heating device, the tool remains mounted on the bearing. The steel strips expand uniformly with the bearing. Optimum tension is thus maintained.

The three tool sizes are matched to different bearing outside diameters, see table below.



Accessories

Long brackets to prevent tilting of self-aligning bearing inner rings (2 pieces)

Ordering designation:
BEARING.MATE.LOCKBAR270

Carrying sling, 1 m long (2 pieces)
BEARING.MATE.SLING.1M

Replacement parts

Short brackets to prevent tilting of self-aligning bearing inner rings (2 pieces)

Ordering designation:
BEARING.MATE.LOCKBAR170

Pack of spare parts
BEARING.MATE.SERVICE.KIT

FAG transport and mounting tool

Ordering designation Transport and mounting tool	Bearing outside diameter		Bearing mass max. kg	Operating temperature max. °C	Workpiece mass kg
	min. mm	max.			
BEARING.MATE250-450	250	450	500	120	6,3
BEARING.MATE450-650	450	650	500	120	6,4
BEARING.MATE650-850	650	850	500	120	6,5

Products · Mounting/Repair Accessories

Gloves

Heat-resistant FAG gloves HANDSCHUH₁

Heat-resistant FAG gloves are particularly suitable for the handling of heated rolling bearings or other parts in mounting or dismantling.

The outside comprises rugged polyester and can withstand temperatures up to 150 °C. The inside is made from comfortable cotton.

The principal characteristics are:

- Resistant up to 150 °C
- Lint-free
- Asbestos-free
- Comfortable
- Cut-resistant

Ordering designation
HANDSCHUH₁



Heat-resistant and oil-resistant FAG gloves FAG HANDSCHUH₂

Heat-resistant and oil-resistant FAG gloves are particularly suitable for the handling of heated rolling bearings or other parts in mounting or dismantling.

Their principal characteristics derive from the multiple layer construction comprising different fibres.

The principal characteristics are:

- Resistant up to 250 °C
- Non-flammable
- Heat-resistant even when damp
- Authorised for use with mechanical (DIN EN 388) and thermal (DIN EN 407) influences
- Cotton-free
- Cut-resistant

Ordering designation
HANDSCHUH₂



Products · Mounting/Repair Accessories

Mounting paste · Anti-corrosion oil

FAG mounting paste

This mounting and multi-purpose paste has proven valuable particularly for the mounting of rolling bearings. It facilitates the sliding of bearing rings and prevents stick-slip, scoring, wear and fretting corrosion. It also gives good protection against corrosion. It is pale in colour and does not cause contamination.

The mounting paste is applied in a very thin layer such that the metallic sheen turns matt. The paste can be used at temperatures between $-30\text{ }^{\circ}\text{C}$ and

$150\text{ }^{\circ}\text{C}$. It is resistant to water, steam and many alkaline and acid agents.

Available in:
70 g tubes
250 g tubes
400 g cartridges
1 kg cans

Ordering designation:
ARCA.MOUNTINGPASTE.70G
ARCA.MOUNTINGPASTE.250G
ARCA.MOUNTINGPASTE.400G
ARCA.MOUNTINGPASTE.1KG



FAG anti-corrosion oil

The anti-corrosion oil is suitable particularly for unpacked rolling bearings. It can also be sprayed on bright metal surfaces of devices, machines and machine elements to give long term anti-corrosion protection when stored indoors. It is not generally necessary to wash anti-corrosion oil out of rolling bearings since it behaves neutrally towards all conventional rolling bearing greases and oils.

It can be easily and effectively removed using alkaline solvents and neutral cleaning agents.

Available in:
0,4 litre spray can with ozone-safe propellant CO_2

Ordering designation:
ARCA.ANTICORROSIONOIL.400G



Products · Lubrication

FAG
400



Lubricants 44

Arcanol rolling bearing greases 44

Lubrication systems 48

Motion Guard SELECT MANAGER 48

Motion Guard COMPACT 49

Motion Guard CHAMPION 51

Motion Guard CONCEPT6 52

Grease dosing devices 53

Grease gun 53

Products · Lubrication Lubricants

Arcanol rolling bearing greases

Special rolling bearing greases like Arcanol at first glance cost a little more than standard greases. But they are worth the price. For with Arcanol you can buy some extra safety as FAG selects only the best from a number of good greases in a series of tests, provides quality assurance and gives lubrication recommendations. Bearings which fail prematurely because they were lubricated with the wrong grease, with all the unpleasant and expensive consequences, increasingly belong to the past.

In co-operation with renowned lubricant manufacturers, we have for many years developed lubricating greases that are particularly suitable for rolling bearings. However, before a new grease is included in the Arcanol programme, it has to pass a series of stringent tests in the FAG lubricant lab.

The greases are tested thoroughly. On our lubricant test rigs FE8 (DIN 51819) and FE9 (DIN 51821), the greases are tested in rolling bearings to find out how they improve service life and reduce friction and wear. Only the best greases are subjected to the following tests under simulated field conditions in far more complicated rolling bearing test rigs. If the results meet the requirements of the stringent FAG specifications, the greases are included in the Arcanol programme. Thus they receive the Arcanol seal of quality.

In addition, we test every single batch to ensure the uniform quality of the product. It is only after the grease has passed this final test that it is allowed to be filled into containers labelled Arcanol. The programme consists of fourteen greases which cover nearly all fields of application in an optimum manner.

The overview on pages 46/47 shows chemical-physical data, fields of application and the conditions for which these greases are suitable. The selection of a suitable grease is considerably facilitated by the electronic INA/FAG rolling bearing catalogue.

- **More than 80% of all rolling bearings are lubricated with grease**
- **Inadequate lubrication causes more than 40% of all cases of rolling bearing damage**
- **Therefore users need lubricants and lubrication recommendations which they can rely on.**
- **Arcanol rolling bearing greases ensure that a bearing can be used to its full capacity**
 - long service life
 - good running behaviour
 - very safe operation

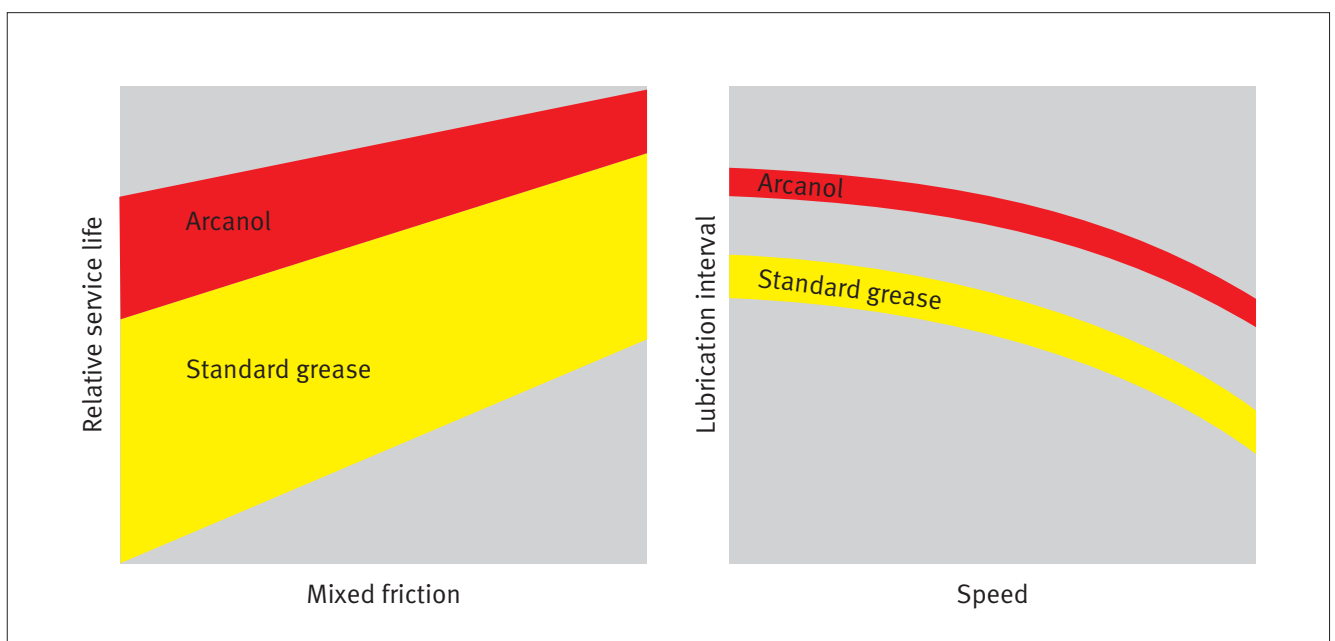

Products · Lubrication

Lubricants

Arcanol rolling bearing greases · Container sizes · Ordering examples

Arcanol rolling bearing greases · Container sizes

Arcanol grease	20 g tube	70 g tube	250 g tube	400 g cartridge	1 kg can	5 kg bucket	10 kg bucket	25 kg hobbock	50 kg hobbock	180 kg drum
MULTITOP			•	•	•	•	•	•		•
MULTI ₂	•		•	•	•	•	•	•		•
MULTI ₃			•	•	•	•	•	•		•
LOAD ₂₂₀					•		•	•		•
LOAD ₄₀₀				•	•	•	•		•	•
LOAD ₁₀₀₀						•		•		•
TEMP ₉₀	•			•	•	•		•		•
TEMP ₁₁₀				•	•				•	
TEMP ₁₂₀					•	•		•		
TEMP ₂₀₀		•			•					
SPEED _{2,6}			•		•			•		
VIB ₃					•	•		•		
BIO ₂				•	•		•	•		•
FOOD ₂				•	•		•	•		•

Other container sizes by agreement.

Arcanol rolling bearing greases · Ordering examples

Ordering designation	Description
ARCA.GREASE.MULTI ₂ .20G	FAG rolling bearing grease Arcanol MULTI ₂ in 20 g tube (50 pieces)
ARCA.GREASE.TEMP ₂₀₀ .70G	FAG rolling bearing grease Arcanol TEMP ₂₀₀ in 70 g tube
ARCA.GREASE.SPEED _{2,6} .250G	FAG Rolling bearing grease Arcanol SPEED _{2,6} in 250 g tube (10 pieces)
ARCA.GREASE.LOAD ₄₀₀ .400G	FAG rolling bearing grease Arcanol LOAD ₄₀₀ in 400 g cartridge (10 pieces)
ARCA.GREASE.BIO ₂ .1KG	FAG rolling bearing grease Arcanol BIO ₂ in 1 kg can
ARCA.GREASE.MULTITOP.5KG	FAG rolling bearing grease Arcanol MULTITOP in 5 kg bucket
ARCA.GREASE.FOOD ₂ .10KG	FAG rolling bearing grease Arcanol FOOD ₂ in 10 kg bucket
ARCA.GREASE.MULTI ₃ .25KG	FAG rolling bearing grease Arcanol MULTI ₃ in 25 kg hobbock
ARCA.GREASE.LOAD ₂₂₀ .180KG	FAG rolling bearing grease Arcanol LOAD ₂₂₀ in 180 kg drum

Products · Lubrication Lubricants

Arcanol rolling bearing greases · Selection table

Overview of Arcanol rolling bearing greases						
	Arcanol MULTITOP	MULTI ₂	MULTI ₃	LOAD ₂₂₀	LOAD ₄₀₀	LOAD ₁₀₀₀
DIN 51825	KP2N-40	K2N-30	K3N-30	KP2N-20	KP2N-20	KP2N-20
Thickener	Lithium soap with EP additives	Lithium soap	Lithium soap	Lithium/ calcium soap with EP additives	Lithium/ calcium soap with EP additives	Lithium/ calcium soap with EP additives
Base oil	Mineral oil+ester	Mineral oil	Mineral oil	Mineral oil	Mineral oil	Mineral oil
Base oil viscosity at 40 °C [mm²/s]	85	ISO VG 100	80	ISO VG 220	400	ISO VG 1000
Consistency (NLGI class)	2	2	3	2	2	2
Operating temperature [°C]	-40...+150	-30...+140	-30...+140	-20...+140	-25...+140	-20...+140
Long term temp. limit [°C]	80	75	75	80	80	80
Characteristic areas of application for Arcanol rolling bearing greases	Universal grease for ball and roller bearings in rolling mills, construction machinery, automotive engineering, spinning and grinding spindles under increased speeds, high loads, low and high temperatures	Universal grease for ball bearings D ≤ 62 mm in small electric motors, agricultural and construction machinery, household appliances	Universal grease for ball bearings D > 62 mm in large electric motors, agricultural and construction machinery, fans	Special grease for ball and roller bearings in rolling mill equipment, rail vehicles under high loads, with wide speed range, high humidity	Special grease for ball and roller bearings in mining machinery, construction machinery under very high loads, moderate temperatures, moderate speeds	Special grease for ball and roller bearings in mining machinery, construction machinery, preferably under shock loads and in large bearings under very high loads, moderate temperatures, low speeds
Low temperatures	++	+	+	O	-	O
High temperatures	O	O	O	O	O	O
Low friction, high speeds	+	O	O	-	-	--
High loads, low speeds	+	O	O	++	++	++
Vibrations	+	O	+	+	+	+
Support for seals	O	O	+	+	+	+
Relubrication facility	++	++	+	+	+	+

ISO VG =
ISO viscosity group

++ extremely suitable
+ very suitable

O suitable

- less suitable
-- not suitable

Products · Lubrication Lubricants

Arcanol rolling bearing greases · Selection table

TEMP90	TEMP110	TEMP120	TEMP200	SPEED2,6	VIB3	BIO2	FOOD2
KP2P-40	KE2P-40	KPHC2R-30	KFK2U-40	KE3K-50	KP3N-30	KPE2K-30	KPF2K-30
Calcium polycarbamide with EP additives	Lithium complex soap	Polycarbamide with EP additives	PTFE	Polycarbamide	Lithium complex soap with EP additives	Lithium/calcium soap	Aluminium complex soap
PAO oil	Ester oil	PAO/ester oil	Fluoro polyether oil	PAO/ester oil	Mineral oil	Ester oil	White oil
130	ISO VG 150	ISO VG 460	400	ISO VG 22	170	58	192
2	2	2	2	2-3	3	2	2
-40...+160	-40...+160	-35...+180	-40...+260	-50...+120	-30...+150	-30...+120	-30...+120
90	110	120	200	80	90	80	70
Special grease for ball and roller bearings	Special grease for ball and roller bearings	Special grease for ball and roller bearings	Special grease for ball and roller bearings	Special grease for ball bearings	Special grease for ball and roller bearings	Special grease for ball and roller bearings	Special grease for ball and roller bearings
in couplings, electric motors, automotive engineering	in electrical equipment automotive engineering	in continuous casting plant	in track rollers in baking machinery, piston pins in compressors, kiln trucks, chemical plant	in machine tools, instruments	in blade adjusters in rotors for wind power plant, packaging machinery	in environmentally hazardous applications	in applications with food contact; H1 to USDA
under high temperatures, high loads	under high temperatures, high speeds	under high temperatures, high loads	under very high temperatures, in chemically aggressive environments	under very high speeds, low temperatures	under high temperatures, high loads, oscillating motion		
++	++	+	++	++	+	+	+
+	++	++	++	0	+	0	-
0	+	-	--	++	-	0	0
0	0	++	+	--	+	0	0
0	0	0	-	-	++	0	0
0	0	0	0	0	0	0	0
0	0	0	0	+	-	+	++

Products · Lubrication Lubrication systems

Motion Guard · Motion Guard SELECT MANAGER

FAG automatic lubricators Motion Guard

Reliable and economical lubrication for a long bearing life

Rolling bearings are reliable machine components that give a long operating life. The most frequent cause of failure is inadequate or incorrect lubrication. Approximately 90 % of all bearings are lubricated with grease. Providing a reliable supply of suitable grease is therefore particularly important.

If an automatic lubricator is used for controlled relubrication, a sufficient quantity of fresh grease is continuously supplied to the contact points of the rolling bearing.

This results in a significant increase in bearing life. These reliable, economical devices give extended lubrication and maintenance intervals and also

prevent undersupply or oversupply of grease. As a result, plant downtime and maintenance costs are reduced. The sparing and environmentally friendly use of lubricants contribute to higher cost-efficiency.

FAG Motion Guard lubricators are individually matched to the bearing location and eliminate the need for costly central lubrication systems. They have a wide range of applications, for example on pumps, compressors and fans, in conveying equipment, vehicles etc.

The single point lubrication systems Motion Guard COMPACT and CHAMPION can be used to dispense eight or all 14 Arcanol greases described on pages 46 to 47. Motion Guard CONCEPT6 is used as a single point or multi-point lubrication system with twelve Arcanol greases.

Advantages of the lubricators

- Individually configured, precise supply to each bearing position immediately after initial operation
- Fully automatic, maintenance-free operation
- Savings on personnel costs compared to manual relubrication
- Various dispensing times can be selected (1, 3, 6 or 12 months; for CONCEPT6: 1 day to 24 months)
- No risk of confusion or contamination of lubricants
- Pressure build-up to 4 bar (COMPACT), to 5 bar (CHAMPION) or to 25 bar (CONCEPT6), thus overcoming any obstructions
- Suitable for connection to the FAG monitoring system Easy Check
- Comprehensive range of accessories

Motion Guard SELECT MANAGER

The software Motion Guard SELECT MANAGER Version 2.0 allows:

- selection of lubricators
- definition of dispensing times and relubrication quantities
- selection of suitable/preferred Arcanol greases
- maintenance of a lubrication and maintenance plan

Detailed information on FAG automatic lubricators is given in publication WL 81 122.



Products · Lubrication Lubrication systems

Motion Guard COMPACT · Lubricators and activation screws

FAG lubricators Motion Guard COMPACT

This automatic lubricator is electrochemically driven. The electrolyte is environmentally friendly citric acid.

The metal housing is filled with 120 cm³ of FAG Arcanol rolling bearing grease.

The dispensing time is determined by the different coloured activation screws.

Automatic lubricators Motion Guard COMPACT are available with suitable lubricants in standard packs of 10 containers.

Ordering examples:

ARCA.LUB.LOAD400

(filled with LOAD400, pack of 10 containers without activation screw)

ARCA.LUB.TEMP90

(filled with TEMP90, pack of 10 containers without activation screw)

COMPACT lubricators filled with Arcanol MULTITOP and MULTI2 are also available in single packs including activation screws, while those with TEMP200 are only supplied in single packs with activation screws.

Ordering examples:

ARCA.LUB.MULTITOP.1M

(filled with MULTITOP, including activation screw for 1 month)

ARCA.LUB.MULTI2.3M

(filled with MULTI2, including activation screw for 3 months)

ARCA.LUB.MULTITOP.6M

(filled with MULTITOP, including activation screw for 6 months)

ARCA.LUB.TEMP200.12M

(filled with TEMP200, including activation screw for 12 months)



ARCA.LUB.TEMP200.6M

Arcanol

Suitable Arcanol greases, chain oils and activation screws

	1M	3M	6M	12M
MULTITOP	•	•	•	
MULTI2	•	•	•	
LOAD400	•	•	•	•
LOAD1000	•	•	•	•
TEMP90	•	•	•	•
TEMP120	•	•	•	•
TEMP200	•	•	•	•
FOOD2	•	•	•	•
CHAINOIL	•	•	•	•

Activation screws

Ordering designations (10 pieces):

ARCA.LUB.ACTIVE.1M

for 1 month (yellow)

ARCA.LUB.ACTIVE.3M

for 3 months (green)

ARCA.LUB.ACTIVE.6M

for 6 months (red)

ARCA.LUB.ACTIVE.12M

for 12 months (grey)
(12M **cannot** be used for MULTITOP and MULTI2!)



Products · Lubrication

Lubrication systems

Motion Guard COMPACT · Versions CLEAR and POLAR

Version CLEAR

The CLEAR version of the lubricator Motion Guard COMPACT is suitable for explosion-protected and corrosion-inducing humidity areas. The lubricator can be used at operating temperatures from 0 to +40°C. The upper temperature limit is determined by the transparent plastic housing with a volume of 100 cm³.

Ordering example:

ARCA.LUB.FOOD2.CLEAR

(filled with FOOD2, pack of 10 containers without activation screw)

In addition to FOOD2, seven other Arcanol grease grades, as listed for COMPACT on page 49, as well as chain oil can be used.

The special activation screws for the CLEAR version with dispensing times of 1, 3 or 6 months are offered separately.

Ordering designation (10 pieces):

ARCA.LUB.ACTIVE.CLEAR.1M

ARCA.LUB.ACTIVE.CLEAR.3M

ARCA.LUB.ACTIVE.CLEAR.6M



Version POLAR

The POLAR version of the lubricator Motion Guard COMPACT is designed for operation in temperatures from -25 °C to +10 °C. The metal housing is filled with 120 cm³ of Arcanol rolling bearing grease MULTITOP (it is only available with this grease).

Ordering designation:

ARCA.LUB.MULTITOP.POLAR

(filled with MULTITOP, pack of 10 containers without activation screw)

For the dispensing time as a function of the actual temperature, see the following table.

Version POLAR

Temperature	Dispensing time
+10 °C	1 week
± 0 °C	2 weeks
-10 °C	6 weeks
-20 °C	14 weeks
-25 °C	26 weeks

The black activation screw must be ordered separately.

Ordering designation (10 pieces):

ARCA.LUB.ACTIVE.POLAR



Products · Lubrication Lubrication systems

Motion Guard CHAMPION · Lubricator drives, LC units, sets and accessories

FAG lubricator Motion Guard CHAMPION

The automatic lubricator Motion Guard CHAMPION is electromechanically driven. The robust, electronically controlled geared motor can be used more than once. It allows the dispensing times to be adjusted depending on the temperature and to 1, 3, 6 or 12 months. It is battery powered and the battery set is replaced whenever the cartridge is changed.

Ordering designation:
ARCA.LUB.DRIVE

Special drive units are available as accessories for machine-controlled operation in explosion hazard areas.

The lubricator Motion Guard CHAMPION is suitable for all the Arcanol rolling bearing greases described on page 46-47 as well as chain oil. Filled LC (Lubricant Cartridge) units with a dispensing volume of 60, 120 and 250 cm³ are available and are screwed onto the drive unit. Once the LC unit is empty, it cannot be refilled.

Ordering examples
(one battery set is included in the delivery):

ARCA.LUB.MULTITOP.LC60
(filled with MULTITOP, 60 cm³)
ARCA.LUB.LOAD400.LC120
(filled with LOAD400, 120 cm³)
ARCA.LUB.VIB3.LC250
(filled with VIB3, 250 cm³)



The complete lubricator, comprising a drive unit, LC unit and battery set, is connected to the lubrication point by means of an adapter or hose.

Ordering designations:
ARCA.LUB.ADAPTER
ARCA.LUB.TUBE
(3 m hose with connectors)



FAG lubricator sets Motion Guard CHAMPION

The automatic lubricator Motion Guard CHAMPION in sizes 120 and 250 cm³ and filled with Arcanol MULTITOP is offered as a complete lubricator set. The sets comprise:

- a drive unit
- an adapter
- an LC unit with battery set

Ordering designations:
ARCA.LUB.MULTITOP.LC120.SET
ARCA.LUB.MULTITOP.LC250.SET

The lubricator CHAMPION has only been tested in conjunction with Arcanol lubricants. Empty LC units for one-off filling are available in the three sizes 60, 120 and 250 cm³, but should only be used after consulting FAG.

Ordering designations:
ARCA.LUB.EMPTY.LC60
ARCA.LUB.EMPTY.LC120
ARCA.LUB.EMPTY.LC250

By agreement, FAG also supplies the lubricator CHAMPION with special filling specifications.

Accessories for Motion Guard COMPACT and CHAMPION

The Motion Guard product range is supplemented by a comprehensive range of accessories. For detailed information, see publication WL 81 122.

Products · Lubrication Lubrication systems

Motion Guard CONCEPT6

FAG lubrication system Motion Guard CONCEPT6

This **single and multi-point lubrication system** can supply up to six lubrication points with lubricant constantly, precisely and irrespective of temperature. The dispensing times can be adjusted to any time between 1 day and 24 months and LC units are available in sizes 250 and 500 cm³.

FAG starter kits Motion Guard CONCEPT6

The starter kits are premounted on a retaining plate and form the basis for the multi-point lubrication system Motion Guard CONCEPT6.



The patented distribution system MP-6 allows independent supply of between two and six lubrication points.

The geared motor in the MP-6 is powered and controlled by the drive unit.



Lubricant is distributed independent of its consistency or solid particle content. If the distributor identifies an obstruction in an individual outlet, this is indicated on the display of the drive unit. The other outlets continue to be supplied.

Ordering designations:
ARCA.LUB.C6-250.KIT
ARCA.LUB.C6-500.KIT

Only the following items must be ordered separately: hose and connectors for the lubrication point and filled LC units in sizes 250 cm³ and 500 cm³.

LC units are available with the 12 suitable Arcanol grease grades (see page 46-47, except for MULTI3 and VIB3).

Ordering examples:
ARCA.LUB.MULTITOP.C6-250
ARCA.LUB.LOAD400.C6-250
ARCA.LUB.SPEED2,6.C6-500
ARCA.LUB.TEMP200.C6-500

By agreement, FAG supplies LC units with other greases whose suitability has been checked.

Version CONTROL

The CONTROL version of the lubricator CONCEPT6 is controlled by the machine, i.e. lubricant is only dispensed while the machine is running. FAG also supplies starter kits for the CONTROL version as a basis for multi-point lubrication systems.

Ordering designation:
ARCA.LUB.C6-CONTROL-250.KIT
ARCA.LUB.C6-CONTROL-500.KIT



For **single point lubrication**, the parts required are ordered individually from the range of accessories.



For detailed information, see publication WL 81 122.

Products · Lubrication

Lubrication systems

Grease dosing devices · Grease gun

FAG grease dosing devices

These devices supply rolling bearings with accurately dosed grease quantities within a range of 10 to 133 cm³. If larger grease volumes are required, the device can be actuated several times. With a pneumatically driven, double-acting piston pump the grease is fed via the dosing valve directly from its container (25 kg or 180 kg) to the area to be lubricated.

The grease dosing device consists of:

- a cap
- a piston
- a dosing valve
- a connecting tube between pump and valve
- a tube, 2.5 m long
- a grease gun

Technical data:

Pump ratio: 10 : 1
 Delivery quantity: 400 cm³/min
 Dosing range: 10 – 133 cm³

Ordering designations:

ARCA.PUMP25
ARCA.PUMP180



ARCA.PUMP180

FAG grease gun with armoured tube

Under difficult operating conditions or rough environmental conditions rolling bearings frequently have to be relubricated via lubrication nipples. Relubrication is easy, clean and swift if an FAG grease gun with an armoured tube is used. These parts meet the requirements of DIN 1283.



Grease gun

Diameter of container 56 mm
 Total length of gun 390 mm
 Delivery 2 cm³/stroke
 Pressure max. 800 bar

The grease gun can be refilled either with bulk grease or with a cartridge in accordance with DIN 1284.

- 500 cm³ of bulk grease or
- 400 g cartridge according to DIN 1284 (diameter 53.5 mm, length 235 mm)

Connection thread G¹/₈
 Mass approx. 1.5 kg

Ordering designation:
ARCA.GREASE-GUN

Armoured tube

Length 300 mm
 Connection thread G¹/₈
 Equipped with a hydraulic grip coupling for a hydraulic-type lubricating nipple according to DIN 71412

Instead of this hydraulic coupling it is also possible to connect sliding couplings for button head lubricating nipples in accordance with DIN 3404 or other connection pieces. These connection pieces can be purchased from specialised retailers.

Ordering designation:
ARCA.GREASE-GUN.HOSE

Products · Alignment



Belt and chain drives **56**

Belt pulley alignment device 56

Belt tension measuring device 57

Shaft couplings **58**

Shaft alignment device 58

Accessories for alignment **60**

Shims 60

Products · Alignment Belt and chain drives

Belt pulley alignment device

FAG belt pulley alignment device Top-Laser SMARTY

Top-Laser SMARTY is an economical measuring device for the alignment of belt pulleys and chain sprockets. Through the use of this device, the wear of belt drives, bearings and seals is reduced. Less vibration is generated and the running time and reliability of the machinery are increased.

Features and advantages:

- Displays parallelism and misalignment of both pulleys
- Significantly quicker and more precise than conventional methods
- Suitable for both horizontally and vertically mounted machinery
- Only one person required for alignment
- Also suitable for non-magnetic sprockets or pulleys

The measuring device can be mounted in just a few seconds. The laser beam can be clearly seen on the target marks. When the laser beam coincides with the slits in the target marks as a result of adjustment, the machine is correctly aligned.

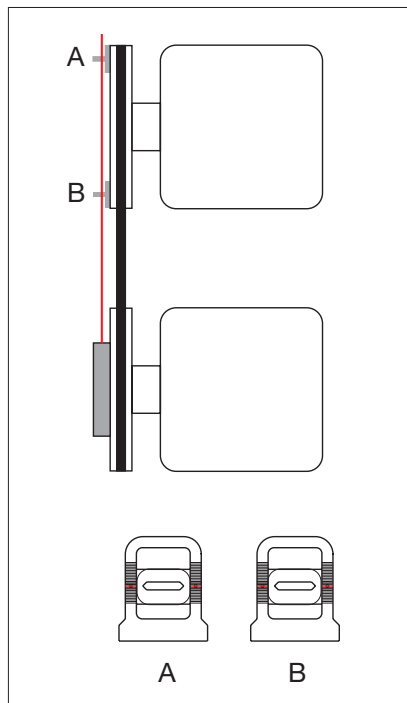

Due to the low mass of the measuring device, the transmitter and target marks can be fixed to non-magnetic drive pulleys using a strong, double-sided adhesive strip.

Ordering designation
Complete laser measuring device
incl.

2 target marks,
2 batteries and user manual in
padded case:

LASER.SMARTY

Replacement part
1 magnetic target mark
LASER.SMARTY.TARGET

For detailed information,
see TI WL 80-55.



Products · Alignment Belt and chain drives

Belt tension measuring device

FAG belt tension measuring device Top-Laser TRUMMY

The robust, handy Top-Laser TRUMMY is an optical-electronic instrument for measuring and setting optimum belt tension (strand force).

Optimum belt tension, like precise alignment of the belt pulleys (see Top-Laser SMARTY, page 56), is an essential precondition for achieving the maximum possible life of the belt drive. There is also less wear of the drive components, energy costs are reduced and cost-effectiveness is increased. The user-friendly Top-Laser TRUMMY can be used in many

locations and comprises a measurement probe and a microprocessor that indicates relevant measurables for belt tension either as frequency [Hz] or force [N]. By means of an impulse (for example by striking the stationary belt), the tensioned belt is excited to natural vibration. The individual static natural frequency thus generated is measured within seconds by the TRUMMY sensor using clock pulse light and displayed. In order to calculate the strand force of the belt drive, the belt mass and length are entered in the microcomputer before measurement. TRUMMY uses these data to calculate the strand force, which is then compared with the specified nominal value.

In comparison with systems operating for example by sound waves, this new measurement technique using clock pulse light is clearly superior, since the measurement result cannot be distorted by disruptive influences. The simple and secure user instructions are given in several languages.

Ordering designation
Laser measuring device in plastic case:

LASER.TRUMMY

For detailed information,
see TI WL 80-55.



Products · Alignment Shaft couplings

Shaft alignment device

FAG shaft alignment device Top-Laser INLINE

The FAG Top-Laser INLINE is a PC-based alignment system for coupled shafts in motors, pumps, ventilators and gearboxes (with rolling bearings).

Advantages:

- Simple to use
- Error-free handling even by untrained personnel due to automatic measurement and positioning process
- More precise alignment than with conventional methods
- Rapid measurement due to continuous rotary motion
- Reduced vibration and friction losses
- Longer machine running times
- Usable with conventional laptops
- Suitable for use in combination with Bearing Analyser

Included in delivery

- 1 transmitter/receiver (incl. 3 m cable)
- 1 reflector
- 2 brackets
- 2 chains (300 mm)
- 4 posts (115 mm)
- 1 software
- 1 case
- 1 serial PC card

All the parts included in the delivery are also available as replacement parts.

Ordering designation
Complete Top-Laser INLINE:
LASER.INLINE

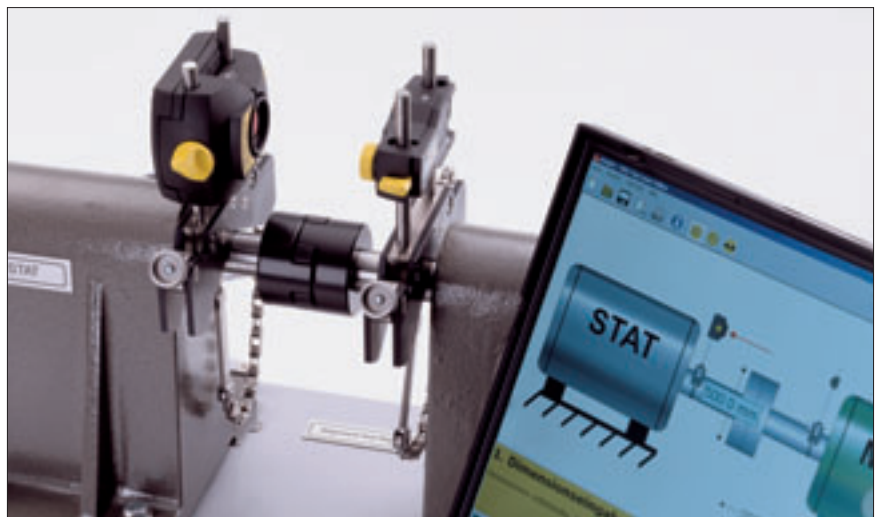

Actions before alignment

Before any alignment operation, any tilting foot (machine foot that lifts off the floor when slackened) should be removed in order to prevent increased vibration tendency and bearing damage due to housing distortion.

The Top-Laser INLINE helps to quickly identify and eliminate the so-called soft foot. It is only necessary to loosen each individual screw foot connection. The computer determines any foot movement. The tilt foot can then be eliminated using shims.

Products · Alignment Shaft couplings

Shaft alignment device

Accessories

The possible applications of the basic device LASER.INLINE are expanded by a comprehensive range of accessories (see table). The accessories can be ordered as a set in a handy, robust case or – individually compiled – as individual parts.

For detailed information, see TI WL 80-55.

Accessories for LASER.INLINE		
Accessories for LASER.INLINE	Included in delivery	Ordering designation
Accessory set, complete	1 piece	LASER.INLINE.ACCESS.SET
Chain, 600 mm long	2 pieces	LASER.INLINE.CHAIN600
Chain, 1500 mm long	2 pieces	LASER.INLINE.CHAIN1500
Post, 150 mm long	4 pieces	LASER.INLINE.POST150
Post, 200 mm long	4 pieces	LASER.INLINE.POST200
Post, 250 mm long	4 pieces	LASER.INLINE.POST250
Post, 300 mm long	4 pieces	LASER.INLINE.POST300
Magnetic holder	2 pieces	LASER.INLINE.MAGNET
Accessory case, empty	1 piece	LASER.INLINE.ACCESS.SUITCASE



Products · Alignment Accessories

Shims

FAG shims Top-Laser SHIMS

Top-Laser SHIMS are used to eliminate any vertical misalignment detected using the FAG Top-Laser devices. These shims are available in seven thickness values (0,05; 0,10; 0,20; 0,50; 0,70; 1,00; 2,00 mm) and four sizes (dimension C = 15, 23, 32 or 44 mm).

Composition of set

The handy case contains 20 shims each in 3 sizes (C = 15, 23 and 32 mm) and 6 thickness values (0,05 to 1,0 mm), i.e. a total of 360 shims, together with one extraction hook.

Ordering designation:

LASER.SHIMS.SET

Individual or replacement parts

As replacement parts, we supply 10 shims each in one of the 4 sizes and one of the 7 thickness values stated above.

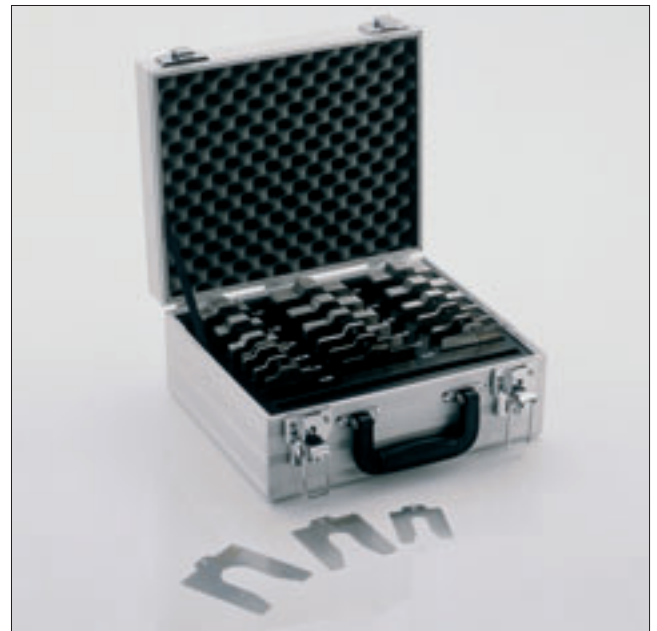
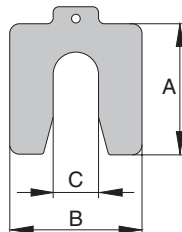

Ordering examples:

10 shims in dimension C = 15 mm and 0,20 mm thickness:

LASER.SHIMS15,0,20

10 shims in dimension C = 44 mm and 0,10 mm thickness:

LASER.SHIMS44,0,10

For detailed information, see TI WL 80-55.

LASER.SHIMS.SET

Ordering designation Set FAG	Dimensions			Thickness	Total quantity Shims	Mass kg
	A	B	C			
LASER.SHIMS.SET	55	50	15	0,05 – 1,0	360	6,7
	75	70	23			
	90	80	32			

LASER.SHIMS Individual or replacement parts

Ordering designation Individual or replacement parts FAG	Dimensions			Thickness	Total quantity Shims	Mass g
	A	B	C			
LASER.SHIMS15...	55	50	15	0,05 – 2,0	10 each	11 – 440
LASER.SHIMS23...	75	70	23			
LASER.SHIMS32...	90	80	32			
LASER.SHIMS44...	125	105	44			

Products · Condition monitoring

Operating condition 62

Temperature measuring devices	62
Digital hand tachometer	63
Sonar device	64

Vibration diagnosis 65

Detector	65
Bearing Analyser	65
Easy Check	66
Easy Check Online	66
DTECT X1	66
WiPro	67
Screen Saver	68
VibroCheck	68



Products · Condition monitoring Operating condition

Temperature measuring devices

FAG infrared thermometer TempCheck PLUS

The FAG infrared thermometer TempCheck PLUS measures the infrared radiation emitted by an object and uses this to calculate the surface temperature. The contact-free measurement makes it possible to easily determine the temperature of difficult to reach or moving objects.

The device is very light (it weighs only 150 g) and can be taken practically anywhere it is needed. The FAG infrared thermometer TempCheck PLUS can measure temperatures in a range between -32 °C and $+530\text{ °C}$. It has a high precision glass optic for accurate contact-free temperature measurement. It is suitable for monitoring the temperature of rolling bearings and other components.

Overview of the advantages of TempCheck PLUS:

- Rapid and precise temperature measurement
- State of the art infrared temperature measurement technology
- Simple to use
- Reduction of unplanned downtime
- Low purchase cost

Ordering designation and scope of delivery:

TEMP.CHECK.PLUS
(measuring device with battery, strap, user manual and carry case)



Safety warning

Do not look into the laser beam or point it in other people's eyes.

FAG temperature measuring device TEMP.MG

This handy device has a display range of -60 to $+1000\text{ °C}$.

The surface temperature sensor TEMP.MG.F, included in the delivery, has a measurement range of -60 to $+300\text{ °C}$.

The device is suitable for measuring the temperature of

- rolling bearings, housings and lubrication systems for operational monitoring
- heated rolling bearings and joints during mounting

The microprocessor-controlled measuring device has a single line display. The touch keyboard has

the following switching functions:

- On/off
- Hold (hold the measurement value in the display)

Ordering designation and scope of delivery:

TEMP.MG
(measuring device with sensor TEMP.MG.F and service case)

FAG temperature sensor as replacement part

(can be ordered individually):
Rapid reaction surface sensor
Ordering designation:

TEMP.MG.F

FAG temperature sensor as accessory

(can be ordered individually, for measuring the temperature of fluids, lubricants etc.):

Immersion/insertion sensor

Ordering designation:

TEMP.MG.TF



For detailed information, see TI WL 80-54.

Products · Condition monitoring Operating condition

Digital hand tachometer

FAG digital hand tachometer TACHOMETER

The speed counter is suitable for two types of operation:

- Direct speed measurement using an adapter, track wheel and measuring tips
- Non-contact optical speed measurement using reflective mark

Direct speed measurement

For direct speed measurement, the supplied adapter must be fitted.

Through contact with the component, the rubber stylus measures the turning speed or determines the surface speed in conjunction with a track wheel.

Non-contact speed measurement

For non-contact measurement, a reflective mark is applied to the machine part to be measured. This mark is detected by photoelectric means using visible red light. The device displays the speed in revolutions per minute.

Ordering designation:

TACHOMETER

Contents: Digital hand tachometer
Adapter for direct 1:1 measurement
Track wheel 1/10 m
Track wheel 6 inch
Rubber stylus
10 reflective marks
User manual
Case

Replacement parts

10 reflective marks
Ordering designation:
TACHOMETER.REFLEX.MARKS



Products · Condition monitoring Operating condition

Sonar device

FAG sonar detector SOUND.CHECK

The sonar detector can be used to check rolling bearing noise very easily, quickly and reliably. Changes in noise due to wear, pitting formation or distortion of the bearing can be detected at an early stage if regular inspection is carried out. In this way, unexpected interruptions in operation and more serious machine damage can be avoided. The device is used in the same way as a doctor's stethoscope.

The tips of the earpiece are placed in the ear canals to provide insulation against background noise. The insulating grip is held like a pencil between index finger and thumb and the sensor is placed firmly on the part to be measured. If a noise is heard, the sensor is moved until its volume reaches a maximum.

Ordering designation:

SOUND.CHECK



Products · Condition monitoring Vibration diagnosis

Detector II · Bearing Analyser III

Condition monitoring by vibration diagnosis

Vibration diagnosis is the most reliable method for identifying machine damage at an early stage. Balance and misalignment defects can be detected accurately, as well as rolling bearing damage and gear tooth defects. In this field, FIS offers a comprehensive product range from simple vibration monitors to complex monitoring systems with a large number of measurement points. FAG vibration measuring devices help to plan maintenance work, extend bearing life, reduce costs and increase plant availability.

In the field of **offline monitoring devices**, FAG offers Detector II and Bearing Analyser III.

The **online monitoring devices** include products from the economical Easy Check range, the digital vibration monitors DTECT X1, WiPro and Screen Saver as well as the online monitoring system VibroCheck.

FAG Detector II

Detector II is a portable vibration measuring device and data collector in one. Using this economical device is straightforward and easy to learn. It weighs approx. 450 g and is highly suitable for monitoring extensive plant where large distances must be covered. Detector II picks up vibration signals at predetermined measurement points and calculates the effective values for vibration rate and acceleration. It can be used to monitor machine vibrations in

accordance with ISO 10816 as well as the rolling bearing condition using envelope signal processing. Temperatures can also be measured by non-contact means using an infrared sensor. The data collected by the device are transferred to a computer. They are then evaluated, analysed and presented in diagrammatic form with the aid of the software Trendline. Any incipient damage can thus be detected at an early stage. Detector II can also be used by personnel who have no experience of vibration measurement. A very useful feature in this respect is the “E-Mail button”. This allows the collected data to be sent to an external diagnosis expert for further analysis.

For detailed information, see TI WL 80-62.

Please direct enquiries to: sales@fis-services.de



FAG Detector II

FAG Bearing Analyser III

Bearing Analyser III is a multi-channel vibration analysis device.

The device is suitable for reliable early diagnosis of damage as well as for troubleshooting on machines. Bearing Analyser III can be used for detailed analysis of complex machinery and plant as well as multi-stage gearboxes and rolling mills. The Bearing Analyser comprises a laptop, the BA III software and a docking station that is connected to the laptop via a data acquisition card. The signals collected are transferred to the laptop and evaluated by the Bearing Analyser software. Bearing Analyser III also offers the option of continuous data recording. The automatic diagnosis system can, together with the integrated database, identify typical patterns of machine damage in the vibration signal and alert the user via the inbuilt traffic light function. In this way, damage can be detected and analysed independently of the absolute level of the signal power.

For detailed information, see TI WL 80-63.

Please direct enquiries to: sales@fis-services.de



FAG Bearing Analyser III

Products · Condition monitoring Vibration diagnosis

Easy Check · DTECT X1

FAG Easy Check series

The FAG Easy Check devices are economical vibration monitors for permanent monitoring of critical machinery in plant with constant operating conditions, e.g. pumps, fans, electric motors etc.

Since Easy Check vibration monitors are easy to mount and operate, they can also be used by employees who have no knowledge of condition monitoring.

The devices monitor vibration in accordance with ISO 10816, the condition of rolling bearings with the aid of envelope signal processing and the temperature at the bearing locations.

The use of Easy Check devices can contribute to a considerable cost reduction since incipient damage is detected at an early stage and the necessary work can be integrated into maintenance planning.

FAG Easy Check

FAG Easy Check is a standalone device that is powered by a battery and applied directly to the critical machine. The vibration monitor



FAG Easy Check

draws attention to any problem by means of LEDs (traffic light function). The status of the LEDs on the Easy Check must be checked at regular intervals.

FAG Easy Check Online

In contrast to the base device, FAG Easy Check Online has an external power supply. Additional alarm outputs for vibration and temperature offer the possibility of presenting alarm conditions on a control station or traffic light device. This eliminates the need for regular inspections and allows the monitoring of difficult to access locations. Using the input, FAG Easy Check Online can be administered remotely, for example, for resetting the alarms, starting the learning phase or activating a measurement cycle.



FAG Easy Check Online

For detailed information, see
TI WL 80-68.

Please direct enquiries to:
sales@fis-services.de

FAG DTECT X1

DTECT X1 allows early detection of damage by selective frequency vibration monitoring based on individually adjustable frequency bands. By means of the selective frequency method, specifically selected machine parts can be monitored. DTECT X1 has characteristics that would normally only be found on significantly more expensive systems. The system is variable and can be specially matched to the requirements of the application. The base device is available with 2 channels, 4 channels or as an 8 channel system with an external multiplexer. All conventional acceleration, velocity and displacement sensors can be attached. It is possible to record process variables such as speed, temperature, torque and pressure. The signal collected by the sensor is broken down into its frequency components by means of Fast Fourier Transformation (FFT).



FAG DTECT X1

Products · Condition monitoring Vibration diagnosis

DTECT X1 · WiPro

It is thus possible to monitor amplitudes within fixed, very narrow frequency bands for specified limit values and trigger an alarm. If necessary, the remote monitoring function can be used to monitor machines without the need for a diagnosis expert on site. Any changes are automatically notified via telecommunication systems (fixed line, mobile or GSM modem) to the operator, plant manufacturer or service provider irrespective of where the system is located throughout the world. Stored and current data can be remotely retrieved and analysed by the FAG Diagnosis Centre.

For detailed information, see TI WL 80-65.
Please direct enquiries to:
sales@fis-services.de

FAG WiPro

WiPro is a cost-effective online monitoring system for the condition-based maintenance of wind turbines.

The system, certified by the AZT (Allianz Zentrum für Technik), can monitor not only the drive train (main bearing, gearbox, coupling, generator) but also vibrations in the tower. If required, other information such as rotor blade speeds or oil quality can be integrated in the condition monitoring. WiPro is equipped with a signal processor and evaluates all measurement signals in the nacelle itself. Due to the intelligent linking of expert knowledge with information from the turbine, it is possible to keep the transfer data volume very small. This is particularly important where a large number of turbines are to be monitored on a permanent basis, allowing transfer data quantities to be kept to a minimum. Due to the different communication options, an appropriate solution can be found for any wind farm.

With WiPro, the operator is kept informed at all times of the condition of the most important components. This means a high level of investment security and active machine protection. The modular concept of WiPro systems allows all types of wind turbines to be retrofitted with the system. Any wind farm can be networked using the WiPro system, whether the turbines are connected using copper cables, fibre optics, ISDN or analogue lines or even if no telephone connection is present at all.

For detailed information, see TI WL 80-66.
Please direct enquiries to:
sales@fis-services.de



FAG WiPro

Products · Condition monitoring Vibration diagnosis

Screen Saver · VibroCheck

FAG Screen Saver

Screen Saver is a vibration measuring system for use on vibrating screens that is matched to the rough environmental conditions of the materials processing industry (mining, cement industry etc.). Since the system detects incipient damage at an early stage, maintenance measures can be planned and unforeseen downtime can be avoided. Vibrating screens or vibratory conveyors are often key components in materials processing. Their continuous functional capability is therefore very important.

Depending on the type of screen, replacement can cost between 20 000 and 150 000 €. Downtime costs, depending on the production site involved, can run up to 13 000 € per hour. Thanks to a special filter technique, the system can differentiate between vibrations caused by the process itself and those that are generated by defective components (gearboxes, bearings, loose parts etc.). The current monitoring status can be viewed both on the monitoring unit (traffic light system) and transmitted to the control



FAG Screen Saver

station or machine controller. The data stored in the monitoring unit can be downloaded offline by employees or sent online via various communication channels such as modem, GSM, TCP/IP etc. to a remote computer for further evaluation and monitoring.

For detailed information, see TI WL 80-69.
Please direct enquiries to: sales@fis-services.de

FAG VibroCheck

The online monitoring system VibroCheck is ideally used wherever a large number of measurement points must be continuously and reliably monitored, such as in rolling mills, paper factories or power stations. In its most expanded form, up to 2048 sensors can be integrated in the system. For the detection of defects such as imbalance and misalignment, VibroCheck generates spectrum-based parameters that are managed within narrow frequency bands according to speed. In addition to general parameter monitoring, the user has available an automatic, rule-based expert system that can monitor up to 20 components per sensor. This allows monitoring of all rolling bearing types and tooth meshes in the vicinity of a sensor in relation to the occurrence of component-specific frequency windows. In addition to vibration signals, other process parameters such as temperature, power, pressure, torque etc. can also be processed. Through remote access, the data can also be analysed by external

service providers or CM experts at other locations.

The display, which is individually tailored to the customer's requirements, gives a user interface that allows rapid overview of the condition of the plant. Depending on the complexity of the plant, this display can be arranged on several levels. Through the high predictive accuracy and early identification of forthcoming damage, optimum use can be made of planned stoppages and downtimes due to failure can be drastically reduced.



FAG VibroCheck

For detailed information, see TI WL 80-67.
Please direct enquiries to: sales@fis-services.de

Products · Maintenance management



CMMS*Interface

70

Products · Maintenance management

CMMS*Interface

CMMS*Interface

With the CMMS*Interface, FIS offers an intelligent link between vibration measurement/analysis and the maintenance management system MAXIMO®.

By means of a software module, the portable FAG vibration measuring device Detector II and its Trendline software is linked to the maintenance management system MAXIMO®.

In addition to the advantages of the two systems in themselves, the link created by the CMMS*Interface generates the following synergy effects:

- Central storage of diagnostic and maintenance data
- Redundancy-free administration of master data
- Fully automatic generation of current routes for Detector II
- Automatic generation/updating of follow-up orders in MAXIMO® in an alarm situation
- Generation of a measurement value history in MAXIMO®



Please direct enquiries to:
sales@fis-services.de

Services

Mounting/Repair 72

Mounting service	72
Repair service	73
Equipment rental	74
Railway wheelset bearing maintenance	75

Lubrication 76

Alignment 77

Condition Monitoring 78

Troubleshooting	78
Balancing	78
Service contract	79
Online monitoring	79
Offline monitoring	79
Measurement concepts	80
Remote diagnosis	80

Maintenance management 81

Maintenance consultancy	81
Maintenance planning and control systems	83

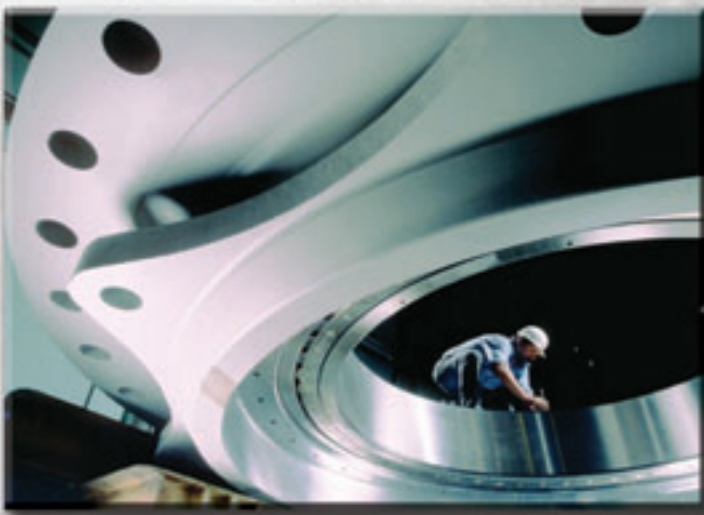

Services · Mounting/Repair

Mounting service

Mounting service

The F'IS Mounting Team offers mounting services for rolling bearings across market sectors. We have extensive experience, for example, in railways, mining, steel and aluminium, wind power, paper etc.

The F'IS mounting personnel are specially trained and will provide reliable assistance, with a rapid response where necessary. The mounting services are provided either at the customer's location or in the F'IS workshop facilities.

The mounting service includes:

- mounting and dismounting of rolling bearings of all types
- approval inspection of adjacent parts (shafts and housings)
- maintenance and inspection of bearing arrangements
- defect analysis on bearing arrangements not running satisfactorily
- advice on rationalisation of mounting operations
- design and manufacture of special tools

The advantages include:

- extended bearing life
- considerable cost reductions
- less unplanned downtime
- increased plant availability
- improved awareness among employees of the correct handling of rolling bearings

Please direct enquiries about the services described to

FAG Kugelfischer AG & Co. oHG

Tel. +49 9721 91-3142 or -2573

Fax +49 9721 91-3809

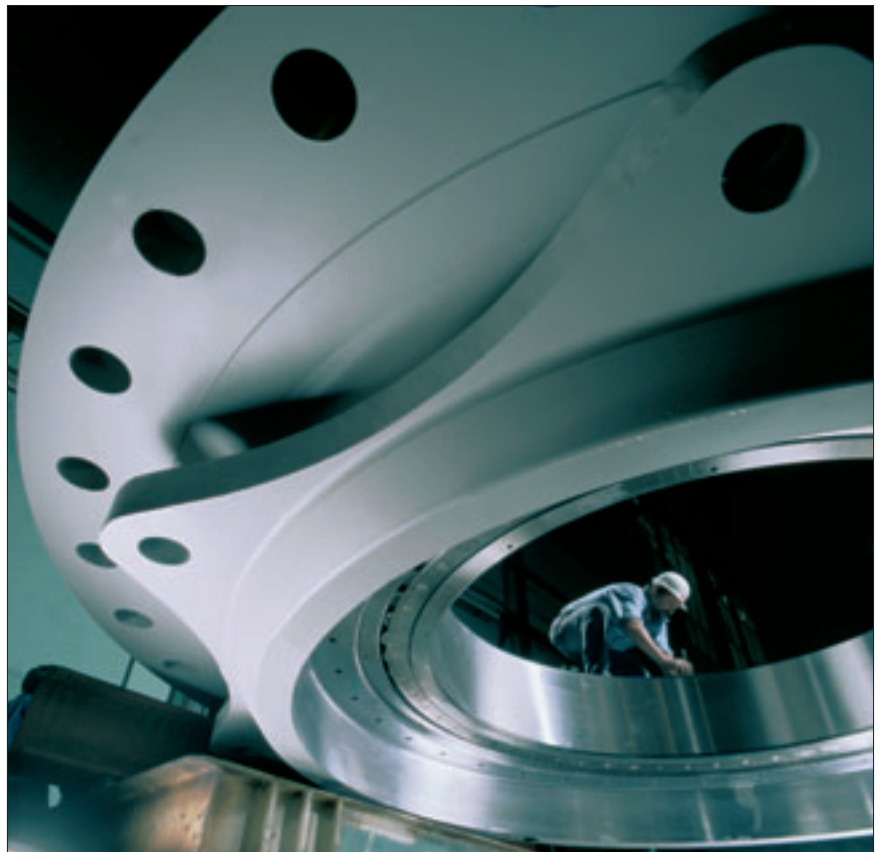

Services · Mounting/Repair

Repair service

Repair service for large rolling bearings

During the maintenance of machinery and plant, many rolling bearings are taken out of service and replaced by new ones as a precaution. This exaggerated safety-awareness blocks any appreciation of the potential cost savings. The fact is that reconditioned bearings generally have the same performance as new ones. The FIS experts repair all types of rolling bearings such as cylindrical roller bearings, spherical roller bearings, tapered roller bearings etc. The FIS experts carry out a damage diagnosis that costs between 100,- € and 500,- €. On this basis, a decision is made as to whether repair is viable or not.

For detailed information, see publication WL 80 151 DA.

Please direct enquiries to:

FAG Industrial Services

Mettmanner Straße 79
42115 Wuppertal
Telephone +49 202 2932-227
Fax +49 202 2932-437
E-Mail: kleine_g@fis-services.de
www.fis-services.de

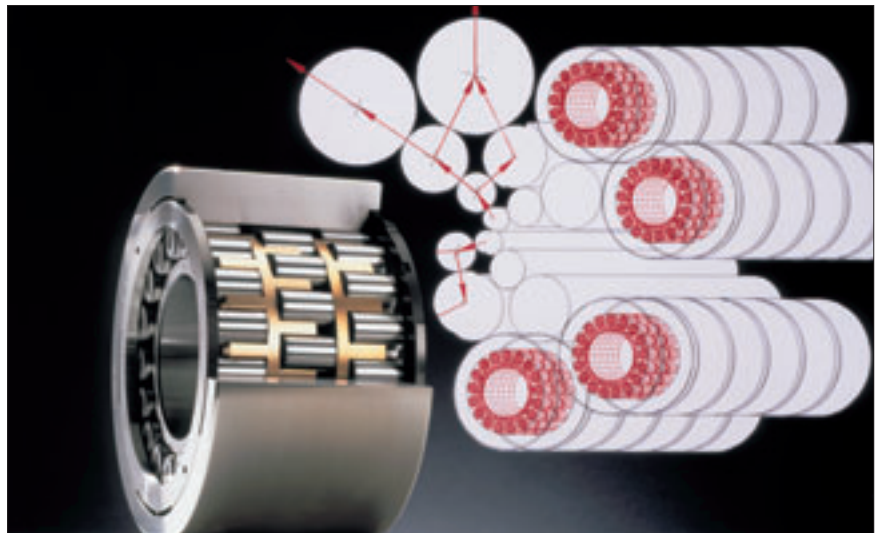

Cylindrical roller bearing back-up roller for Sendzimir rolling mills

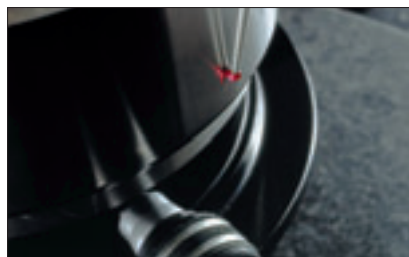

Roundness measurement

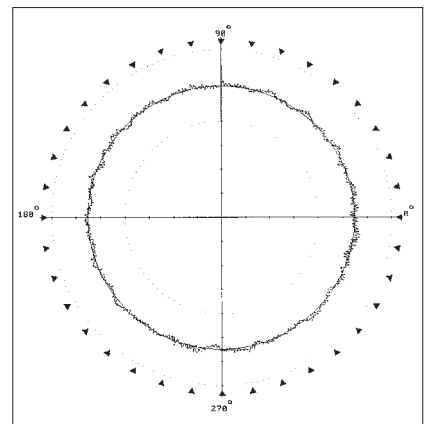

Sensing trace for a spherical roller bearing inner ring



Checking of roller seats



Outer ring grinding



Mounting of a large bearing

Services · Mounting/Repair Equipment rental

Equipment rental

Customers who require special mounting and measuring equipment only infrequently, for example in order to carry out repairs, can rent these from FAG on a weekly basis for a fee.

FAG mainly offers for rent

- taper gauges
- enveloping circle gauges
- hydraulic nuts
- hand pump sets
- heating devices

The equipment is stored at our mounting workshop and its function is checked and maintained by our mounting specialists.

Please direct enquiries about this service to

FAG Kugelfischer AG & Co. oHG

Tel. +49 9721 913142

Service Hotline:

Tel. +49 2407 914999



Services · Mounting/Repair Railway wheelset bearing maintenance

Railway wheelset bearing maintenance

Wheelset bearings for railway vehicles are among the most heavily loaded vehicle parts. Their life can be increased significantly by appropriate and regular maintenance. F'IS therefore offers operators of all railway vehicles the opportunity to have their wheelset bearings professionally dismantled, cleaned and reconditioned. Customers can thus benefit from the high quality maintenance measures and technical expertise of the F'IS employees in the Reconditioning Team.

The F'IS service offer applies to:

- all cylindrical, spherical and tapered roller bearings up to a maximum width of 180 mm and a maximum outside diameter of 420 mm
- products from all rolling bearing manufacturers
- all railway vehicles

The service includes:

- professional dismantling, cleaning and reconditioning of wheelset bearings at the F'IS Service Center in Schweinfurt
- marking of each individual bearing before dismantling
- if required, bearing-specific documentation of all maintenance activities carried out

The advantages include:

- longer life of railway wheelset bearings due to high quality maintenance work
- marking of each individual bearing for cleaning and reconditioning. If required, this provides bearing-specific documentation of all maintenance work carried out
- return of the wheelset bearing ready for mounting after completion of the maintenance work
- short downtimes due to swift implementation of the maintenance process; the emphasis in all maintenance operations is on precision and care
- reduced maintenance costs due to preventive maintenance

Please direct enquiries about the services described to

FAG Kugelfischer AG & Co. oHG

Tel. +49 9721 91-3142 or -2573

Fax +49 9721 91-3809



Services · Lubrication

Lubrication as a service

In more than half of all cases, inadequate lubrication is the cause of unplanned machine downtime.

The use of suitable greases for different operating and environmental conditions as well as know-how of when, how frequently and with what quantities bearings should be lubricated, make it possible to significantly extend the life of rotating machine elements.

Specialised employees offer their service across market sectors and have special experience, for example, in the areas of railways/transport, power transmission, steel and aluminium, paper, wind power, agriculture and forestry, the food and delicacies industry as well as mining and extractive equipment. F'IS services include the selection and installation of lubricants and lubrication systems, the lubrication of bearing positions, the preparation of lubrication and maintenance plans, lubrication point management, lubrication consultancy and lubricant investigations and tests.

A comprehensive selection of high quality FAG greases Arcanol specially tested and selected for use in rolling bearings is available. The consistent quality of Arcanol lubricants is ensured by ongoing investigation on special test rigs. The use of names that are easily remembered and matched to the application allows rapid grease selection. The F'IS team also deals with special requirements such as rapidly biodegradable greases and

greases for use in the food industry, on the basis of ongoing innovation.

FAG rolling bearing greases Arcanol are also suitable for use in FAG automatic lubricators Motion Guard.



The software **Motion Guard SELECT MANAGER** Version 2.0 allows:

- selection of lubricators
- definition of dispensing times and relubrication quantities
- selection of suitable/preferred Arcanol greases
- operation of a lubrication and maintenance plan

Use of the F'IS lubrication service can prevent the failure of rotating machine parts and increase productivity while reducing lubrication costs.



Services · Alignment

Alignment

Incorrect alignment of belts and shafts are among the most common causes of unplanned machine downtime.

Correct alignment considerably increases the life of rotating machine parts. The highly qualified FIS employees are able to reduce to a minimum the increased vibration levels that are induced by deformations in the shafts, machine bodies, foundations etc. They position drive components such as motors, couplings, gearboxes etc. such that the drive operates with as little wear as possible.

The FIS experts locate and eliminate misalignments on machines using two or more coupled shafts and belts. In addition to detailed analysis of causes, the FIS service includes alignment of belts and shafts on pumps, ventilators, compressors, electrical machinery etc. as well as the detection and correction of positional deviations in belts and shafts using FIS vibration and laser measurement devices. FIS also offers various measuring devices that can be used personally to align defective elements.

With the aid of the FIS alignment service, you can avoid unplanned machine downtime due to misalignment. You thereby considerably increase plant availability while reducing your maintenance costs.



For detailed information, see publication WL 80 316

Please direct enquiries to:
sales@fis-services.de

Services · Condition Monitoring Troubleshooting · Balancing

Condition Monitoring

The failure-free and optimised operation of complex machinery and plant can only be achieved by means of condition-based maintenance.

The key method used by F'IS in condition-based maintenance is vibration diagnosis. This method makes it possible to detect incipient damage in machinery at a very early stage. The customer is thus able to act rather than having to react. For example, damaged components can be replaced as part of planned downtime.

In particular, vibration diagnosis helps to avoid unplanned downtime and expensive consequential damage, increase productivity and improve plant availability.

F'IS offers a comprehensive and flexible range of services in the field of condition-based maintenance.



For detailed information, see publication WL 80 315 DA.

Troubleshooting

If malfunctions or other problems occur on a machine, a detailed defect analysis must be carried out as soon as possible. This can be likened to detective work. Based on many years experience in different sectors and applications, the F'IS diagnosis experts are well versed in such troubleshooting tasks.

Their analysis incorporates various information, for example from visual observation, examination of the machine documentation and discussions with machine operators.

Problems or malfunctions in machine operation often become apparent through changes in vibration behaviour, unusual temperature patterns or similar phenomena. The F'IS experts therefore also carry out measurements on the machine.

The measurement methods used will depend on the particular application. The F'IS experts are familiar with all measurement techniques, from vibration measurement to torque analysis or endoscopy. As a result, they can quickly identify malfunctions and prepare possible solutions.

Endoscopy

If damage has been detected but the component cannot be replaced in the short term for production reasons, the precise extent of the damage can be determined using endoscopy.

The interior of the machine is examined using digital video endoscopes. Based on their knowledge and experience, the F'IS diagnosis experts can precisely

assess the condition of individual components such as rolling bearings and gear teeth.

Force and torque measurement

If damage accumulates at a particular point in the plant, a design problem may be surmised. Overloading of bearing positions that was not taken into consideration in the design of the plant can be detected with the aid of force and torque and incorporated in an improved plant structure.

Balancing

Imbalance is one of the main sources of malfunctions that lead to unexpected failure of machine elements. Correct balancing gives a decisive increase in the life of rotating machine parts. This increases the productivity and plant availability. The F'IS experts reduce to a normal level the increased vibration that occurs due to contamination, wear, repairs, etc. They detect and eliminate the causes of imbalances on machines at speeds of 1 to 100 000 rpm such as pumps, ventilators, compressors, turbines, motors etc. Irrespective of the sector, F'IS offers not only a detailed analysis of the reasons for the malfunction but also the removal of imbalances in any plane of adjustment. If necessary, various F'IS analysis devices can be used to prepare further diagnoses.

For detailed information, see publication WL 80 317.

Please direct enquiries to: sales@fis-services.de

Services · Condition Monitoring

Service contract · Online monitoring · Offline monitoring

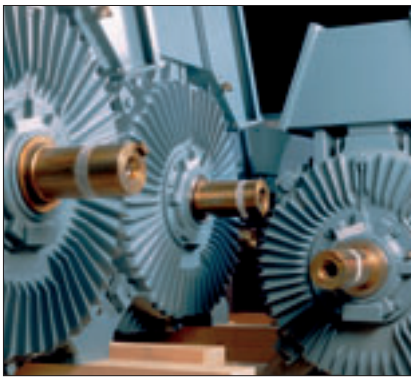

Service contract

In order to fulfil the wide range of customer requests and needs, F'IS offers customer-specific service contracts. Once the initial situation has been determined (customer interest, customer objectives etc.), F'IS submits a proposal for partnership over an extended period. Everything is possible: from training and support plans to build up know-how in vibration diagnosis according to a precisely defined plan, to contracts for complete monitoring of bearing conditions. It is also possible to set up an individual online area for service customers (with login via the F'IS website). Information on the current monitoring status can then be obtained at any time. The costs for service contracts vary according to their composition.

Online monitoring

In the case of production-critical machinery, permanent monitoring by means of vibration diagnosis is indispensable in many cases. Access at any time to precise information on the condition of the machine offers

uniquely effective protection against unplanned downtime and expensive production stoppages. If there is also a risk of consequential damage, an online monitoring system pays for itself in just a few months. Depending on the area of application, F'IS offers a wide range of solutions, including standalone solutions for smaller equipment, medium-sized systems with up to 8 channels that can be extended on a modular basis and also complex monitoring systems with up to 2048 sensors. In addition to giving expert advice in selecting the right system, F'IS also implements plant monitoring. This includes not only hardware selection but also system configuration and, if necessary, its integration into existing systems. Depending on know-how, the customer can either carry out plant monitoring himself or enlist the F'IS monitoring service. All of the F'IS monitoring systems have e-service functionality, allowing external monitoring by F'IS experts under favourable terms.

Offline monitoring

The failure of individual machines is not always critical for production. The failure of so-called “B” or “C” category plant items does not lead directly to stoppages and does not therefore bring expensive consequential damage. For such machine parts, the more economical offline monitoring is generally recommended. In this case, costs and benefits are in an optimum ratio. In offline monitoring, machinery is examined and assessed by vibration analysis at regular intervals, for example every 4 weeks. This regularity gives more in-depth knowledge of the normal condition of the machine, allowing deviations to be easily detected. When preparing the offline monitoring concept, the selection of measurement points and monitoring accessories as well as the definition of the measurement interval play a decisive role. It is not absolutely essential to have expertise on site. In the case of irregularities in measurements and trend analyses, F'IS offers the e-service. At the push of a button, all relevant data are exported from

Services · Condition Monitoring Offline monitoring · Measurement concepts · Remote diagnosis

the database and sent by e-mail to the F'IS diagnosis centre, where it is subjected to expert analysis. The customer is promptly sent easily understandable and authoritative diagnosis reports by e-mail. Based on teamwork with the F'IS experts, excellent analytical know-how is soon achieved. F'IS also offers support in data acquisition and carries out regular on-site measurements if the customer's internal personnel cannot be made available.

Measurement concepts

If the decision is made in favour of condition-based maintenance, the important concept phase begins. The aim is to reduce maintenance outlay and increase machine availability. A comprehensive cost/benefit analysis shows the optimum monitoring strategy for each area and gives an overview of the requirements for the equipment to be used. Numerous parameters influence the selection of the systems to be used, such as the importance of the machine for the production flow, the consequential damage that may occur and the value of the

machine. The F'IS consultancy team takes sufficient time to clarify with the customer all the existing questions. A plan is jointly drawn up for the introduction or the improvement of existing vibration monitoring systems. In particular, the distinction between online and offline monitoring has a major influence on the monitoring quality as well as on the costs of monitoring.

Remote diagnosis

Due to modern communication technology and the e-service functionality of F'IS products, F'IS is able to remotely monitor practically any plant, such as offshore wind turbines. From the F'IS diagnosis centre, the F'IS experts can access the customer's monitoring systems at any time and view the current status of the plant. The F'IS systems diagnose any deviation from the normal condition and forward the diagnosis automatically via mobile, telephone line or Internet connection to the F'IS diagnosis centre. In such cases, the expert team is automatically informed and can quickly prepare an in-depth

analysis. Depending on the urgency, different stages of the agreed escalation plan are put into action. Thus the customer is provided in a short space of time with the important information on the condition of the plant and any recommended counteractive measures.



Services · Maintenance management

Maintenance consultancy

Maintenance consultancy

Maintenance consultancy by F'IS helps to make costs more transparent and design maintenance more effectively. The F'IS team moves beyond classical consultancy and places the emphasis on technical perspectives.

The consultancy process starts with a comprehensive analysis of the relevant processes. Building on this base, the F'IS team prepares

customer-specific improvement concepts with the aim of integrating individual solutions within an overall solution. F'IS provides support not only during the implementation phase but also with an ongoing partnership.

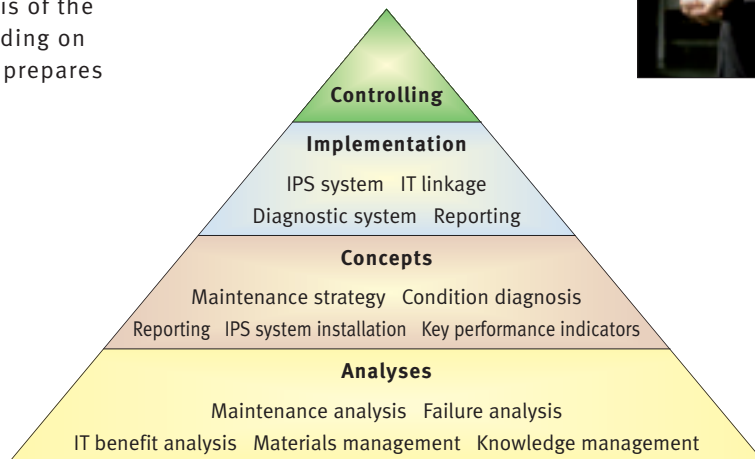
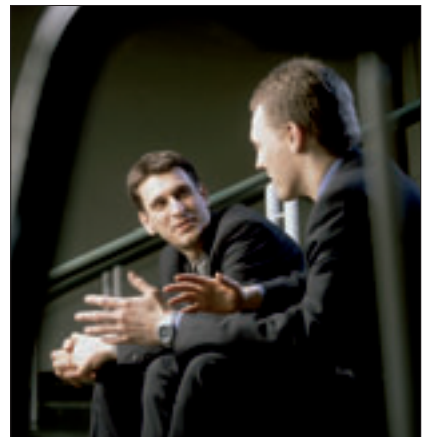

Phases in a consultancy process

Analyses

The F'IS team holds discussions with employees on site and analyses the available documents. The analysis includes subjects such as:

- business processes, costs, personnel structure, tasks/responsibilities, machine utilisation
- commercial and production measurables
- technical support for processes
- utilisation of IT and measurement systems
- maintenance strategies

- knowledge management
- measurables systems relevant to maintenance
- co-operation between departments

Thanks to their experience, the F'IS consultants are in a position to evaluate the information obtained and place it into the overall context. Anonymous data from other companies and sectors are also taken into account for comparison. As requested by the customer, the results are presented at a management and/or plant level.

Services · Maintenance management

Maintenance consultancy

Concepts and implementation

The concepts prepared by F'IS consultants with the customer are aligned to the situation and vision of the customer. There are no standard processes that are imposed on the customer. Each customer is given individual treatment. The concepts prepared are implemented in partnership with the customer.



Maintenance strategy:

- ABC analysis of plant stock in relation to priorities
- RCM (Reliability Centered Maintenance)
- FMEA (Failure Mode and Effects Analysis)
- Condition-oriented maintenance

Introduction concept for a Computerized Maintenance Management System (CMMS):

- Software selection
- Master data structures
- Strategy for planned maintenance and inspection tasks
- Specification and implementation of interfaces
- Inclusion of old data

IT linkage:

- Selection of software based on the catalogue of requirements
- Preparation of a thorough data model
- Specification of interfaces between software packages
- Specification of the necessary hardware

Plant monitoring concepts:

- Analysis of plant weak points
- Selection of appropriate monitoring points
- Definition of limit values
- Definition of suitable monitoring methods
- Selection of suitable technology

Improvement of reporting system:

- Key performance indicator systems
- Automated printed key performance indicators reports for management
- Electronic reporting via the Internet
- Benchmarking against partner companies



Maintenance of concepts

In order to maintain the optimisation of costs and benefits achieved in the long term, regular assessments are carried out after the implementation phase.

These measures are carried out by the customer himself, while the F'IS consultants are at the customer's disposal as a neutral partner. Maintenance controlling can be carried out through extension of the reporting system by means of systems of maintenance-relevant key performance indicators and benchmarking projects.

It is important that maintenance controlling is continually being checked in terms of its significance and effect on the process.

Services · Maintenance management Computerized Maintenance Management Systems (CMMS)

IPS systems

In the field of Computerized Maintenance Management Systems (CMMS), F'IS apply their profound technical knowledge to offer analysis of customer-specific requirements independent of the manufacturer. On this basis, the F'IS team achieves a CMMS optimised and tailor-made for the customer.

The F'IS service covers both complete solutions in the form of CMMS implementation as well as individual modules for the following areas:

Systems integration

Through the implementation of interfaces, for example to ERP (Enterprise Resource Planning) systems, the CMMS is integrated into the IT environment of the

Company. This allows holistic assessment and data analyses in a complete system. Redundant data maintenance and multiple inputting of data can be avoided. Process operations are standardised and optimised, and the exchange of information across departments is improved.



Mobile solutions

With the use of electronic checklists and a handheld PC, data can be collected during an inspection such that damage processing and feedback takes place with ongoing acquisition. The data determined and checked for consistency are transferred via a workplace PC into the CMMS database.

The mobile system ensures thorough IT support to the maintenance process and thus avoids the extensive use of paper and time in manual order processing. Data quality and analysis potential are increased through the use of standardised coding.

Establishment/expansion of the reporting system

The integration of reports into the CMMS provides an authoritative reporting system that offers versatile possibilities for data analysis and representation. Typical applications in this field include evaluation and failure analyses with multi-stage reports, stock and master data lists as well as internal and external business papers. Reports can be generated quickly and easily, the quality of information is improved by electronic completion of forms and the use of standardised reports conforms to the requirements of certification.



Services · Maintenance management Computerized Maintenance Management Systems (CMMS)

Other services on CMMS

- Release and database platform changeover
- CMMS modifications and expanded functions
- Data analysis and corrective data maintenance
- Implementation of automated processes
- Training of your personnel to user and administrator level

Please direct enquiries to:
sales@fis-services.de

Training



Overview	86
Training descriptions	87
Mounting/Repair	87
Lubrication	88
Alignment	88
Condition Monitoring	89
Maintenance management	92
Training aids	93

Training · Overview

F'IS offers, in relation to the product and service range, both standard training and customer-specific training. The individual training units are based on a modular concept with the result that customers can compile their

own customised training course on the basis of these training components. The training courses are offered both at FAG Group locations and also on site at our customers. The current training programme including dates for the

standard training courses can be found at www.fis-services.de in the section Training.

Overview of the most important F'IS training courses		
Overview of the most important F'IS training courses	Training format	
Training module	Standard	Individual
Mounting and repair		
Basic training: Rolling bearing technology	•	•
Basic training: Spindle bearing technology	•	•
Rolling bearing maintenance for rail vehicle maintenance personnel (general)	•	•
Rolling bearing maintenance for TAROL bearings	•	•
Product training: Mounting tools		•
Lubrication		
Product training: FAG lubrication systems Motion Guard		•
Product training: FAG lubricants Arcanol		•
Alignment		
Product training: FAG Top-Laser TRUMMY, SMARTY and INLINE		•
Condition Monitoring		
Vibration Analysis o		•
Vibration Analysis I	•	•
Product training: FAG Easy Check		•
Product training: FAG Detector II	•	•
Product training: FAG Bearing Analyser III	•	•
Product training: FAG DTECT X1	•	•
Product training: FAG WiPro		•
Product training: FAG Screen Saver		•
Product training: FAG VibroCheck		•
Maintenance management		
User training for implemented CMMS		•
System administrator training		•

Detailed information on the individual training courses can be found on the following pages.

Training · Training descriptions

Mounting / Repair

Mounting / Repair

Basic training:

Rolling bearing technology

This training communicates basic knowledge on rolling bearings and their use. Our rolling bearing experts will explain types, characteristics and designations of rolling bearings. In the practically-based part of the training, correct mounting and dismounting will be communicated. Rolling bearing failures will be discussed, together with their symptoms and causes.

Training content: Basic knowledge of standard rolling bearings and their mounting / dismounting

Target group: Head foremen, foremen and mounting personnel from maintenance shops and interested employees

Duration: 1 – 2 days

Basic training:

Spindle bearing technology

In this training, the participants will acquire basic knowledge of spindle bearings and their use. Our spindle bearing experts will explain types, characteristics and designations of spindle bearings. In the practically-based part of the training, correct mounting and dismounting of spindle bearings will be communicated. Specific spindle bearing failures will be discussed.

Training content: Basic knowledge of spindle bearings and their mounting, dismounting and maintenance.

Target group: Head foremen, foremen and mounting personnel from maintenance shops and interested employees

Duration: 1 day

Rolling bearing maintenance for rail vehicle maintenance personnel (general)

This training covers the maintenance of wheelset bearings based on cylindrical and tapered roller bearings. Rolling bearing experts from Application Engineering – Railway will communicate current knowledge on the bearings and their application. Experienced setting supervisors will pass on their knowledge of manual work for rolling bearing maintenance and show correct handling using selected demonstration items.

Training content: Maintenance of wheelset bearings based on simple cylindrical and tapered roller bearings

Target group: Head foremen, foremen and mounting personnel from rail vehicle maintenance workshops

Duration: 1 – 2,5 days

Rolling bearing maintenance for TAROL bearings

The subject of this training is the maintenance of TAROL wheelset bearings. These double row tapered roller bearing units are adjusted, greased and sealed on both sides. Rolling bearing experts from Application Engineering - Railway will communicate current knowledge on the bearings and their application. Experienced setting supervisors will pass on their knowledge of manual work for the maintenance of TAROL bearings and show the particular aspects of this maintenance using selected demonstration items.

Training content: Maintenance of TAROL wheelset bearings

Target group: Head foremen, foremen and mounting personnel from rail vehicle maintenance workshops

Duration: 1 day

Product training: Mounting tools

This training focuses on various tools for the correct mounting and dismounting of rolling bearings. Particular emphasis is placed on the correct use of tools on a day-to-day basis. The content of customer-specific training is always agreed with the customer.

Training content: Technically correct use of mounting and dismounting tools

Target group: Head foremen, foremen and mounting personnel from maintenance shops and interested employees

Duration: By agreement



Training · Training descriptions

Lubrication · Alignment

Lubrication

Product training
FAG lubrication systems
Motion Guard

This training covers the FAG lubrication systems “Motion Guard” in relation to functionality, possible applications, usage and handling. This course will enable the participants to correctly select and use the various products in the lubrication system “Motion Guard“. Thus unplanned machine downtime due to defective lubrication is avoided.

Training content: Safe handling and framework usage conditions of FAG lubrication systems “Motion Guard“

Target group: Head foremen, foremen and mounting personnel from maintenance shops and interested employees

Duration: By agreement



Product training:
FAG lubricants Arcanol

In this training, the participants will acquire further knowledge of the FAG lubricant family “Arcanol” in relation to possible applications, usage and handling. Following the course, the participants will be able to select the correct grease for their particular application.

Training content: Selection and framework usage conditions of the FAG lubricant family “Arcanol”

Target group: Head foremen, foremen and mounting personnel from maintenance shops and interested employees

Duration: By agreement

Alignment

Product training
FAG Top-Laser SMARTY
FAG Top-Laser TRUMMY
FAG Top-Laser INLINE

This course conveys well-founded knowledge on the alignment of belt drives and shafts and the measurement of belt tension. The functionality, possible applications and handling of the measuring systems Top-Laser TRUMMY, SMARTY and INLINE are explained. Following the course, the participants will be able to carry out the required alignment work using the measuring systems.

Training content: Safe handling and framework usage conditions of the measuring systems

“FAG Top-Laser SMARTY”,
 “FAG Top-Laser TRUMMY”,
 “FAG Top-Laser INLINE”.

Target group: Head foremen, foremen and mounting personnel from maintenance shops and interested employees

Duration: By agreement



Training · Training descriptions

Condition Monitoring

Vibration Analysis o

This training gives an overview of conventional vibration diagnosis methods, their essential advantages and boundary conditions for the use of vibration diagnosis as part of condition-based maintenance.

Training content: Basic overview of vibration diagnosis methods

Target group: Technicians and engineers from maintenance department and interested employees

Duration: 1 day

Vibration Analysis I

Building on the training unit “Vibration Analysis o“, this course covers in greater depth the principles of vibration diagnosis with emphasis on frequency analysis. Based on practical examples, the participants will learn to differentiate machine defects and damage such as bearing failure, imbalance, gear teeth defects, alignment and coupling defects using measurement signals.

Training content: Detection of machine defects and damage using vibration diagnosis based on frequency analysis.

Target group: Technicians and engineers from maintenance department and interested employees

Duration: 2 days

Product training FAG Easy Check/ FAG Easy Check Online

This training covers the advantages and boundary conditions for the use of the vibration measuring system “FAG Easy Check”. Following the course, the participants will be able to correctly apply the vibration diagnosis system in relation to the application.

Training content: Correct usage/handling of the vibration measuring system “FAG Easy Check”

Target group: Technicians and engineers from maintenance department and interested employees

Duration: By agreement



Product training: FAG Detector II

Well-based knowledge on the measuring system “FAG Detector II“ in relation to functionality, possible applications and usage/handling is communicated in this course. The participants will then be able to identify machine defects and damage based on trend analysis using the measuring system.

Training content: Advantages and boundary conditions of vibration diagnosis and the safe handling of the measuring system “FAG Detector II” for detection of machine defects and damage using vibration diagnosis based on parameters

Target group: Technicians and engineers from maintenance department and interested employees

Duration: 2 days



Training · Training descriptions

Condition Monitoring

Product training FAG Bearing Analyser III

This training builds on the training unit “Vibration Analysis I” and communicates in-depth knowledge on the measuring system “FAG Bearing Analyser III” in relation to functionality, possible applications and usage/handling. Following the course, the participants will be able to identify machine defects and damage in detail based on trend analysis using the measuring system.

Training content: Safe use of the “FAG Bearing Analyser III” to detect machine machine defects and damage using vibration diagnosis based on frequency analysis.

Target group: Technicians and engineers from maintenance department and interested employees

Duration: 1 day

Product training FAG DTECT X1

On the basis of the training unit “Vibration Analysis I”, this course gives well-founded knowledge both on vibration diagnosis as well as the online measuring system “FAG DTECT X1” in relation to functionality, possible applications and usage/handling. In particular, the versatile configuration possibilities of the system are communicated intensively in practical usage. In addition, the principles of communication technology for teleservice are presented.

This course will enable the participants to identify machine defects and damage in detail based on trend analysis using the measuring system by remote diagnosis and online.

Training content: Extensive knowledge of online vibration diagnosis and safe use of the “FAG DTECT X1” for detection of machine defects and damage by remote access.

Target group: Technicians and engineers from maintenance department and interested employees

Duration: 4 days

Product training FAG WiPro

This course is based on the training module “Vibration Analysis I” and conveys knowledge both on vibration diagnosis and the online measuring system “FAG WiPro” in relation to functionality and possible applications in the wind power sector as well as usage/handling. Particular attention is paid to the system configurations required in a wind turbine on the basis of practical examples.

In addition, the principles of communication technology for teleservice are presented. Following the course, the participants will be able to identify in detail machine defects and damage on wind turbines based on frequency analysis by remote diagnosis and online.

Training content: Profound knowledge of online vibration diagnosis and safe use of the “FAG WiPro” for detection of machine defects and damage by remote access in the wind power sector.

Target group: Technicians and engineers from maintenance department and interested employees

Duration: 4 days

Training · Training descriptions

Condition Monitoring

Product training FAG Screen Saver

On the basis of the training unit “Vibration Analysis I”, this training gives well-founded knowledge both on vibration diagnosis and the online measuring system “FAG Screen Saver” in relation to functionality and possible applications in the vibratory screens sector as well as usage/handling. Particular attention is paid to the system configurations required in vibratory screens on the basis of practical examples. In addition, the principles of communication technology for teleservice are presented. Following the course, the participants will be able to identify in detail machine defects and damage on vibratory screens by remote diagnosis and online.

Training content: Competent knowledge of online vibration diagnosis and safe use of the “FAG Screen Saver” for detection of machine defects and damage by remote access in the vibratory screens sector.

Target group: Technicians and engineers from maintenance department and interested employees

Duration: 4 days

Product training FAG VibroCheck

On the basis of the training module “Vibration Analysis I”, in this course participants will gain in-depth knowledge both on online vibration diagnosis and the measuring system “FAG VibroCheck” in relation to functionality, possible applications and usage/handling. In addition, the principles of communication technology for network-based measuring systems are presented. Following the course, the participants will be able to configure the online monitoring system in relation to automated detection of machine defects and damage and analyse the measurement data.

Training content: Extensive knowledge of online vibration diagnosis and safe use of the “FAG VibroCheck” including configuration of the automatic evaluation algorithms for timely detection of machine defects and damage.

Target group: Technicians and engineers from maintenance department and interested employees

Duration: By agreement

Training · Training descriptions

Maintenance management

User training for implemented CMMS

This course focuses on the setup and use of CMMS implemented at the customer. The content is defined upon customer's request.

Training content: Setting up and using a CMMS

Target group: At customer's option

Duration: By agreement

CMMS administrator training

This training covers the support and maintenance of the CMMS implemented at the customer. The content is defined upon customer's request and taken from the areas of database management, Internet technology, server support and authorisation concepts.

Training content: Supporting and maintaining a CMMS

Target group: System administrators and key users

Duration: By agreement



INA/FAG Technical Training Centre, Hirschaid

Training · Training aids

Rolling bearing mounting cabinet and mounting sets: Basic course for vocational training

Plenty of literature is available on the correct mounting of rolling bearings but there is usually a lack of components for trainees to practice on realistically. For this reason the FAG training shop instructors have prepared a basic course. The objective of this basic course is to convey the knowledge required for suitable bearing selection, appropriate mounting and dismounting, and bearing maintenance. The course is split into two parts: a theoretical section deals with the fundamental knowledge of rolling bearings and a practical section imparts the fundamental skills needed for mounting and dismounting. In the theoretical section great significance was set on merging technical drawing, computing and mechanical engineering into one training unit. The practical section consists of practising the mounting and dismounting of common

bearing types with mechanical and hydraulic equipment on model-like simplified mating parts of rolling bearings (shafts, housings). The teaching material is based on smaller instruction steps and does not exceed the standard required in vocational training today. Other units such as gearboxes, pumps, spindles, car wheels etc. can be prepared for practical training on the basis of this basic course.

Handbook 1 (Theoretical part)

- Mechanical engineering
- Technical computing
- Technical drawing

Handbook 2 (Practical part)

- Mounting of bearings with a cylindrical bore
- Mounting of bearings with a tapered bore
- Hydraulic method
- Practical training with shafts and housings

Technical data

Mounting cabinet:
Dimensions 1135×710×380 mm
Mass (including contents) 94 kg
Suitable for 10 mounting exercises:
5 with shafts
2 with housings
3 with shafts and housings
Smallest shaft diameter: 15 mm
Largest shaft diameter: 55 mm

Ordering designation
(mounting cabinet with contents and angle plate):
MOUNTING.CABINET

Further demonstration models for training are available on request. Please contact: sales@fis-services.de



Training · Training aids

Mounting sets 1 und 2

The trainer can use the FAG mounting sets 1 and 2 – **individual exercises** from the FAG mounting cabinet – to demonstrate the

mounting and dismounting of rolling bearings during teaching or have the apprentices carry these out. The shaft and housing parts can be clamped in a vice for mounting.

Mounting set 3

Mounting set 3 is an **additional exercise** to the FAG mounting cabinet and facilitates the mounting of a self-aligning ball bearing in a housing.

Mounting set 1:

Shaft with housing

Suitable for the following exercises:

- Selection of fits
- Checking the bearing positions
- Mounting the bearing on the shaft
- Axial location of the bearing
- Fitting of a rotary shaft seal
- Assembly (locating bearing)
- Dismounting using extractor

Mounting set 2:

Hydraulic mounting

Suitable for the following exercises:

- Mounting with the aid of pressure screws
- Mounting using a hydraulic nut
- Setting and checking the radial internal clearance
- Axial location using a locknut and tab washer
- Dismounting using an oil injector

Mounting set 3:

Plummer block housing

Suitable for the following exercises:

- Checking the bearing position
- Mounting of adapter sleeve and bearing
- Mounting as locating bearing
- Mounting as non-locating bearing
- Mounting as through shaft
- Mounting in housing closed on one side
- Dismounting of bearing and adapter sleeve

Ordering designation:

MOUNTING.CABINET.SET1



Ordering designation:

MOUNTING.CABINET.SET2



Ordering designation:

MOUNTING.CABINET.SET3



Training videos:

1 × 1 of rolling bearings

The film is particularly suitable for communicating initial basic knowledge on rolling bearings. It presents all types of bearings and highlights their characteristic features.

Ordering designation:

VIDEOFILM201D

Mounting and dismounting of rolling bearings

The film explains the most important rules of mounting in

simple pictures and text. Cardinal mistakes are named in simple unambiguous terms. It is clearly shown, step by step, how various bearings are to be correctly mounted.

Ordering designation:

VIDEOFILM202D

Hydraulic method for mounting and dismounting of large rolling bearings

Using trick and real scenes, the film shows all the common methods and devices in hydraulic mounting:

pumps, hydraulic nuts, special extraction devices, adapter and extraction sleeves.

Furthermore, the film explains what has to be borne in mind with tapered or cylindrical shaft seats and how the radial clearance or the axial drive-up distance is measured correctly and expertly to ensure a perfect fit of parts on the shaft.

Ordering designation:

VIDEOFILM203D

Publications · Index of FAG products



Publications 96

Index of FAG products 97



Publications

Publications

Publication WL 80 100	Mounting and dismounting of rolling bearings
Publication WL 80 102	How to mount and dismount rolling bearings hydraulically
Publication WL 80 123	All about rolling bearings – The FAG training offer on the theory and practice of rolling bearings
Publication WL 80 134	FAG video on the mounting and dismounting of rolling bearings
Publication WL 80 135	FAG video on the hydraulic method for the mounting and dismounting of rolling bearings
Publication WL 80 151	Repair service for large rolling bearings
Publication WL 81 115	Rolling bearing lubrication
Publication WL 81 116	Arcanol · Grease tested for use in rolling bearings
Publication WL 81 122	Motion Guard – Automatic Lubricator
Publication WL 82 102	Rolling bearing damage

Technical Information

TI WL 00-11	FAG videos on rolling bearings
TI WL 80-14	Mounting and dismounting of spherical roller bearings with tapered bore
TI WL 80-38	Mounting of self-aligning ball bearings using adapter sleeves
TI WL 80-50	FAG pressure generators
TI WL 80-53	Rolling bearing mounting cabinet and mounting sets – Basic course for vocational training
TI WL 80-54	FAG heating devices
TI WL 80-55	FAG alignment tools
TI WL 80-56	FAG tools for mechanical mounting and dismounting of rolling bearings
TI WL 80-57	FAG hydraulic nuts
TI WL 80-58	FAG extraction devices
TI WL 80-62	FAG Detector II – the “mobile phone” among data collectors
TI WL 80-63	Rolling bearing diagnosis with the FAG Bearing Analyser III
TI WL 80-65	Modern, condition-oriented monitoring of plant and machinery using FAG digital vibration monitors
TI WL 80-66	FAG WiPro – Wind Turbine Protection
TI WL 80-67	FAG VibroCheck online monitoring system for heavy industry
TI WL 80-68	FAG Easy Check · FAG Easy Check Online
TI WL 80-69	FAG Screensaver
TI WL 80-70	Measurement and dimensioning of tapered studs using the FAG taper gauge MGK9205

CD-ROMs

CD Medias 4.0	Electronic INA/FAG rolling bearing catalogue
CD – WLS	Rolling bearing learning system
CD – MGSM 2.0	FAG Motion Guard Select Manager
CD – MM 1.0	FAG Mounting Manager

Index of FAG products

Index of FAG products		
Ordering designation	Product	Page
ABZIEHER...	Mechanical extractor for small bearings	12
AGGREGATE.E700	Electrically driven FAG hydraulic unit	27
AGGREGATE.P1000/2500	Compressed air driven hydraulic unit	27
ARCA.ANTICORROSIONOIL.400G	Spray can containing Arcanol anti-corrosion oil	42
ARCA.GREASE.BIO2...	Special grease for environmentally hazardous applications	47
ARCA.GREASE.FOOD2...	Special grease for applications with food contact	47
ARCA.GREASE.LOAD220...	Special grease for high loads, large speed range	46
ARCA.GREASE.LOAD400...	Special grease for very high loads, moderate speeds	46
ARCA.GREASE.LOAD1000...	Special grease for very high loads, low speeds	46
ARCA.GREASE.MULTITOP...	Universal grease for high speeds, high loads, high temperatures	46
ARCA.GREASE.MULTI2...	Universal grease for bearings under normal loads ($D \leq 62$ mm)	46
ARCA.GREASE.MULTI3...	Universal grease for bearings under normal loads ($D > 62$ mm)	46
ARCA.GREASE.SPEED2,6...	Special grease for very high speeds, low temperatures	47
ARCA.GREASE.TEMP90...	Special grease for low and high temperatures	47
ARCA.GREASE.TEMP110...	Special grease for low and high temperatures, high speeds	47
ARCA.GREASE.TEMP120...	Special grease for high temperatures, high loads	47
ARCA.GREASE.TEMP200...	Special grease for very high temperatures	47
ARCA.GREASE.VIB3...	Special grease for high loads, high temperatures, oscillating motion	47
ARCA.GREASE-GUN	Arcanol grease gun	53
ARCA.GREASE-GUN.HOSE	Arcanol reinforced hose	53
ARCA.LUB.	Lubricator COMPACT with grease charge, without activation screw	49
ARCA.LUB.CLEAR	Lubricator COMPACT CLEAR	50
ARCA.LUB.LC60 (~LC120, ~LC250)	LC unit with 60 (120, 250) cm ³ of grease for lubricator CHAMPION	51
ARCA.LUB.LC120.SET (~LC250.SET)	Lubricator set CHAMPION with LC unit 120 (250) cm ³	51
ARCA.LUB.ACTIVE.1M (~3M, ~6M, ~12M)	Activation screws for lubricator Motion Guard COMPACT	49
ARCA.LUB.ACTIVE.CLEAR.1M (~3M, ~6M)	Activation screws for lubricator Motion Guard COMPACT CLEAR	50
ARCA.LUB.ACTIVE.POLAR	Activation screw for lubricator Motion Guard COMPACT POLAR	50
ARCA.LUB.C6-250.KIT (~500.KIT)	Multi-point lubrication system CONCEPT6 with LC unit 250 (500) cm ³	52
ARCA.LUB.C6-CONTROL-250.KIT (~500.KIT)	Multi-point lubrication system CONCEPT6, (machine controlled) with LC unit	52
ARCA.MOUNTINGPASTE...	Arcanol mounting paste	42
ARCA.PUMP25 (~180)	Grease dosing device for 25 (180) kg grease container	53
AWG25	Induction heating device for workpieces up to 600 kg mass	33
AWG40	Induction heating device for workpieces up to 1200 kg mass	33
AWG100	Induction heating device for workpieces up to 3000 kg mass	33

Index of FAG products

Index of FAG products		
Ordering designation	Product	Page
BEARING.MATE250-450 (450-650; 650-850)	Transport and mounting tool for rolling bearings of outside diameter 250-450 mm (450-650 mm; 650-850 mm)	40
COIL..../...LOW..	Electric induction heating device with low voltage	35
COIL.TRANSFORMER...	Single phase dry transformer for heating device with low voltage	35
FEELER.GAUGE100 (~300)	Feeler gauges, 100 (300) mm long, 13 (23) blade	36
FIS.BAIII.SET.001	Bearing Analyser III	65
FIS.DETECTORII.SET.1MB	Detector II	65
FIS.EASYCHECK.V1	Easy Check	66
FIS.EASYCHECK.ONLINE.SET	Easy Check Online	66
FIS.X1.K2.BASIC (~K4.BASIC, ~K8.BASIC)	DTECT X1 2-channel (4-channel, 8-channel)	66
FITTING.TOOL.ALU.SET10-50	Mounting tool set (aluminium) for rolling bearings, bore size 10-50 mm	8
FITTING.TOOL.STEEL.SET10-50	Mounting tool set (steel) for rolling bearings, bore size 10-50 mm	8
HANDSCHUH1 (~2)	Heat-resistant (heat-resistant and oil-resistant) gloves	41
HEATER10	Induction heating device for workpieces up to 10 kg mass	32
HEATER20	Induction heating device for workpieces up to 20 kg mass	32
HEATER35	Induction heating device for workpieces up to 35 kg mass	32
HEATER150	Induction heating device for workpieces up to 150 kg mass	32
HEATER300	Induction heating device for workpieces up to 300 kg mass	33
HEATER.PLATE	Heating plate (1500 W)	31
HEATING.RING....	Heating ring for inner ring of cylindrical roller bearing or needle roller bearing	34
HEATING.RING.PASTE.20ML	Heat conducting paste (20 ml expendable syringe)	34
HYD.NUT...	Hydraulic nut with metric internal thread	19
HYD.NUT...HEAVY	Hydraulic nut, reinforced design with smooth bore	19
HYD.NUT...INCH	Hydraulic nut with inch size internal thread	19
HYD.NUT.DISPLACE.GAUGE	Displacement gauge for HYD.NUT	20
KLR...	Taper ring gauge	36
LASER.INLINE	Shaft alignment device	58
LASER.SMARTY	Belt pulley alignment device	56
LASER.SHIMS...	Shims for Top-Laser alignment devices	60
LASER.TRUMMY	Belt tension measuring device	57
LOCKNUT.DOUBLEHOOK.KM..	Double hook wrench for locknut KM..	11
LOCKNUT.DOUBLEHOOK.KM...KIT	Double hook wrench kit for locknut KM..	11
LOCKNUT.DOUBLEHOOK.KM...SET	Double hook wrench sets (for locknuts KM5-KM8 / KM9-KM13)	11

Index of FAG products

Index of FAG products		
Ordering designation	Product	Page
LOCKNUT.FACE.PIN...	Jointed face wrench for precision locknut LNP...	10
LOCKNUT.FLEXI.HOOK...	Jointed hook wrench for locknut KM.. or precision locknut LNPG...	10
LOCKNUT.FLEXI.PIN...	Jointed pin wrench for precision locknut AM..	10
LOCKNUT.HOOK.KM...	Hook wrench for locknut KM.. or precision locknut LNPG...	9
LOCKNUT.SOCKET.KM...	Socket wrench for locknut KM..	9
MGA 31	Enveloping circle gauge for outer enveloping circle	39
MGI 21	Enveloping circle gauge for inner enveloping circle	39
MGK 132 (~133)	Taper gauge for 90...510 mm (27...205 mm)	38
MGK9205.12.SET (~30.SET)	Taper gauge set for large studs, taper 1:12 (1:30)	37
MOUNTING.CABINET.D (E, F, NL)	Mounting cabinet with contents and mounting bracket for basic course in German (English, French, Dutch)	93
MOUNTING.CABINET.SET1 (~SET2, ~SET3)	Training case with rolling bearing, mounting tool, ...	94
OILINJECTOR1600 (~2500)	Oil injector 1600 bar (2500 bar)	24
OILINJECTOR...VALVE	Valve nipple	24
OILINJECTOR...SET	Set comprising oil injector and valve nipple	24
PULLER.HYD...	Hydraulic extractor	15
PULLER.INTERNAL.SET10-100	Internal extractor set (for bearings with bore 10 to 100 mm)	14
PULLER.TRISECTION...	Three-section FAG extraction plate for hydraulic and mechanical extractors	17
PUMP1000... (~1600..., ~2500...)	Hand pumps and accessories	25
PUMP2500.0,2L.SET	High pressure pump set (2500 bar)	26
PUMP4000...	High pressure pump (4000 bar) and accessories	26
PUMP.ADAPTER...	Pressure device accessory, adapters	28
PUMP.HOLDER.2 (~3)	Pump holder without (with) manometer connector	29
PUMP...MANO...	Manometer	29
PUMP.NIPPLE...	Pressure device accessory, reduction nipples	28
PUMP.PIPE...	Pressure device accessory, high pressure hoses	30
PUMP.SLEEVE.CONNECTOR...	Pressure device accessory, sleeve connectors for hand pumps	30

Index of FAG products

Index of FAG products		
Ordering designation	Product	Page
SNAP.GAUGE...-...	Snap gauge	38
SNAP.GAUGE.MASTER.DISK..	Master disc for snap gauge	38
SOUND.CHECK	Polyscope sonar device	64
TACHOMETER	Digital hand tachometer	63
TAROL.MOUNTING.AGGREGATE	Mobile hydraulic unit for batch mounting of TAROL bearings	27
TEMP.CHECK.PLUS	Infrared temperature measuring device, contact-free	62
TEMP.MG	Temperature measuring device, contact type	62
VIDEOFILM201D	1 × 1 of rolling bearings	94
VIDEOFILM202D	Mounting and dismounting of rolling bearings	94
VIDEOFILM203D	Hydraulic method for mounting and dismounting	94

FAG Kugelfischer AG & Co. oHG

Postfach 1260

D-97419 Schweinfurt

Georg-Schäfer-Straße 30

D-97421 Schweinfurt

Service Hotline:

Phone +49 2407 9149-99

Fax +49 2407 9149-59

E-Mail support@fis-services.de

www.fis-services.de

Every care has been taken to ensure the correctness of the information contained in this publication but no liability can be accepted for any errors or omissions. We reserve the right to make modifications in the interests of technical improvement.

© by FAG 2005.

Reproduction in whole or in part without our authorisation is prohibited.

WL 80 250/2 EA