

## ● Metalastik® type Cushymount™



### Features

Provides relatively large deflections with high load capacity and long service life.

Incorporates integral adjustable buffer which limits horizontal and vertical movements of the suspended equipment under shock loading without the need for external devices (i.e. links or buffers).

The mounting assembly consists of four bonded rubber to metal circular springs loaded in shear and compression to give optimum load-deflection properties in both vertical and horizontal directions.

The rubber spring elements are protected from physical damage and oil/fluid contamination by the robust S.G. iron castings in which they are housed.

A wide range of load/deflection requirements is covered by a single-sized unit using three types of spring in rubber compounds of varying stiffnesses.

### Metalastik® type Cushymount™

Designed principally to provide high levels of isolation against vibrations arising in heavy rotating machinery, the Cushymount™ is extensively used on a wide range of installations including :

- Medium speed diesel engines
- Marine main propulsion engines
- Marine auxiliaries

Also used for isolating vibration and noise from winches and other heavy machinery and for insulating deck houses on board ship from vibration and noise.

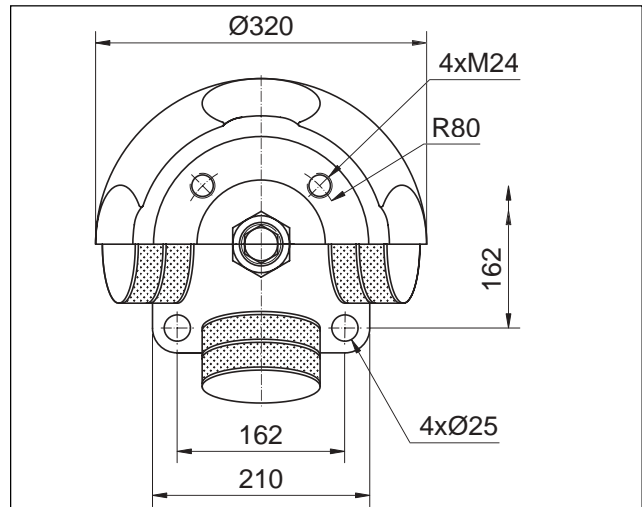
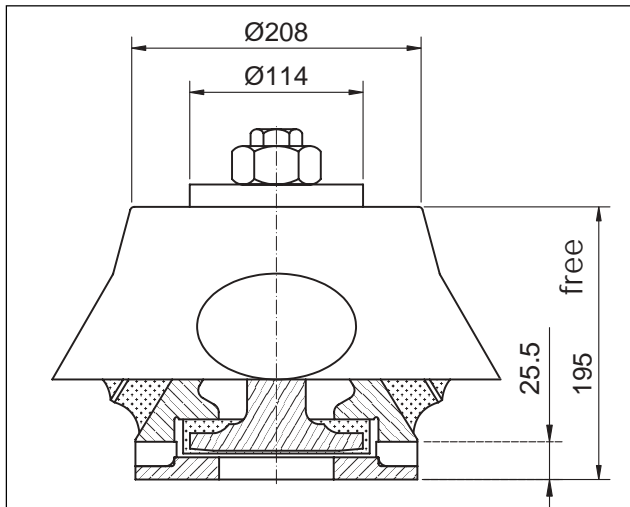

All dimensions in mm

Product No.	Nominal Hardness	Weight kg	Static Vertical Stiffness (kN/m)	Dynamic Vertical Stiffness (kN/m)	Maximum Static Load (kN)
17-1468	45	37	590	700	10.5
17-1468	55	37	880	1160	15.7
17-1469	55	37	1680	2060	27.5
17-1470	45	37	2450	2850	36.8
17-1470	55	37	3530	4400	55
17-1470	65	37	5200	7000	70.5